

C型减速器安装要领

C TYPE REDUCER INSTALLATION GUIDE

为了充分发挥RVC型减速器的性能，对装配精度、安装方法、润滑以及必封进行最佳设计是十分重要的。
 In order to make fully use of RVC type reducer, it is very important to do optimal design of assembly precision, installation method, lubrication.
 请认真阅读以下注意事项。Please carefully read the following notes.

■ 装配精度 Assembly Precision

RVC型减速器的安装侧部件请按附图D.1进行设计。如果装配不良会造成振动、噪声、齿隙等问题。

The installation of side components of RVC type reducers shall be designed based on drawing D.1. Poor assembly will cause shaking, noise and tooth gap, etc.

● 图 D.1: RVC系列装配精度 Figure D.1: RVC series assembly precision

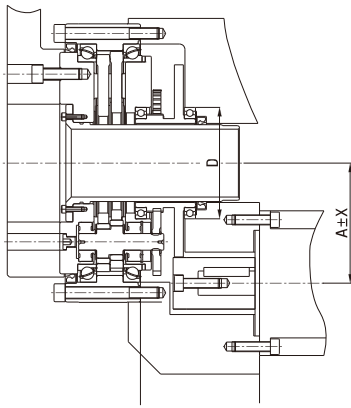

(A为减速机中心到电机中心的距离)
 (A is the distance from the center of the speed reducer to the motor center)

● 表 D.1: RVC系列装配精度尺寸表 Table D.1: RVC series assembly precision size table

(单位 Unit: mm)

型号 Model	项目 Item	中心间距离公差 Center Distance Tolerance	同心度公差 Concentric Tolerance	平行度公差 Parallelism Tolerance
		X	a	b
150BX-RVC		±0.03	Max0.03	Max0.03
180BX-RVC				
220BX-RVC				
250BX-RVC				
350BX-RVC				
440BX-RVC				
520BX-RVC				

● 图 D.2: 装配示例 Figure D.2: Assembly example

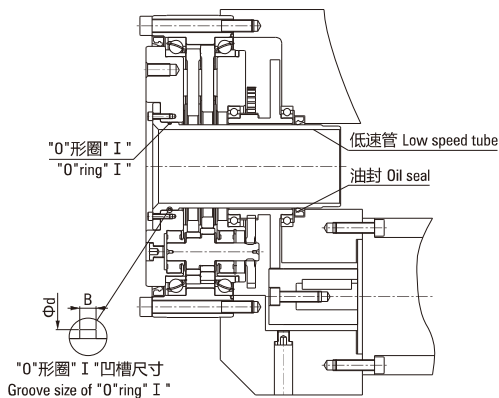

■ 装配要领 Assembly Method

• RVC型减速器安装在配套部件时的标准图例参见图D.2。装配时，请务必按指定量注入润滑脂。

RVC type reducer installed on the supporting parts of standard legend for see figure D.2. When assembly, please be sure to inject the specified amount of grease.

• 图D.2, 图D.3表示了"O"型圈的密封位置，因此请参照进行密封设计。Figure D.2, figure D.3 shows the "O" type of ring seal position, so please refer to the seal design.

• 结构上不能使用"O"型圈时，请使用表C.3的液体密封等密封剂。The structure can not be used "O" ring, please use the form C.3 liquid sealing sealant.

■ 低速管装配示例 Example Of Low Speed Tube Assembly

低速管用于保护通过中空部位的电缆以及密封减速器内部的润滑脂。图D.2是低速管的安装参考示例。

Low speed tube for protection through the hollow part of the cable and the lubrication grease inside the seal reducer. Figure D.2 is a reference example for the installation of a low speed tube.

■ 输出轴螺栓紧固装配示例：图D.3

Output Shaft Bolt Fastening Assembly Example: Figure D.3

● 图 D.3: 装配示例 Figure D.3: Assembly example

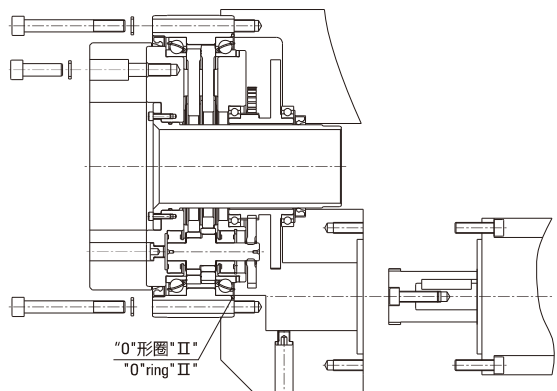

● 表D.2: “O”型圈(I)密封尺寸表(mm): Table D.2: "O" - shaped ring (I) sealing size table (mm)

机型 Model		150BX-RVC	180BX-RVC	220BX-RVC	250BX-RVC	350BX-RVC	440BX-RVC	520BX-RVC
O形圈 O ring	代号 Code							
	公称号码 Nominal number	CO-0625	CO-0634	CO-0643	S70	G95	G135	G145
	线径 Wire diameter	Φ2.4	Φ2.4	Φ3.5	Φ2.0	Φ3.1	Φ3.1	Φ3.1
凹槽尺寸 Groove size	内径 Internal diameter	Φ29.7	Φ42.2	Φ59.6	Φ69.5	Φ94.4	Φ134.4	Φ144.4
	宽度B Width B	3.2	3.2	4.7	2.7	4.1	4.1	4.1

● 表D.3: “O”型圈(II): Table D.3: "O" - shaped ring (II)

机型 Model	适用“O”型圈 Apply The "O" Shape Ring
150BX-RVC	AS568-048
180BX-RVC	AS568-163
220BX-RVC	AS568-169
250BX-RVC	AS568-173
350BX-RVC	AS568-277
440BX-RVC	AS568-281
520BX-RVC	G460、B2401

中心齿轮、输入齿轮 Central Gear, Input Gear

● 中心齿轮、输入齿轮的精度 Center gear, input gear precision

如果中心齿轮、输入齿轮的精度不良,就会产生噪声、齿隙,所以需要按以下精度进行设计。

If the center gear, the input gear's precision is bad, can produce the noise, the tooth gap, therefore needs to carry on the design according to the following precision.

表D.4 中心齿轮、输入齿轮的精度。

Table D.4 center gear, the accuracy of the input gear.

● 表D.4: 中心齿轮、输入齿轮的精度 Table D.4: Center gear, input gear precision

配合公差 Fit Tolerance X	同心度公差 Concentric Tolerance a	中心齿轮小齿轮 Central Gear Pinion 精度等级 Precision Grade	中心齿轮大齿轮 Central Gear 精度等级 Precision Grade	输入齿轮 Input Gear 精度等级 Precision Grade
h6	Max0.03	GB/T10095 8级 level	GB/T10095 7级 level	GB/T10095 8级 level

● 表D.5: 输入齿轮与中心齿轮大齿轮的齿隙(公法线) Table D.5: Gear gap of the input gear and the big gear of the central gear (normal line)

机型 Model	齿隙(公法线) Tooth Gap (Common Law) (mm)
150BX-RVC	0.035~0.090
180BX-RVC	0.040~0.110
220BX-RVC	0.050~0.130
250BX-RVC	0.060~0.140
350BX-RVC	0.075~0.180
440BX-RVC	
520BX-RVC	

输出轴通孔螺栓坚固型装配, 请咨询公司相关技术人员。

Output shaft through hole bolt solid assembly, please ask the company related technical personnel.

● 图 D.4: 中心齿轮、输入齿轮的精度

Figure D.4: Center gear, input gear precision

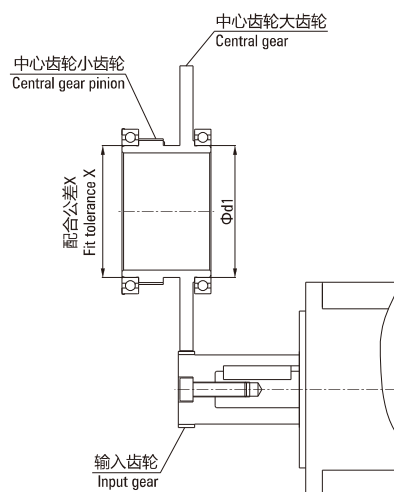

● 表D.6: 中心齿轮小齿轮的齿轮参数

Table D.6: Gear parameters of central gear pinion

机型 Model	齿轮模数 Gear Modulus m	齿轮 Gear z	变位系数 Coefficient Of Variation x
150BX-RVC	1.00	48	-0.04
180BX-RVC	1.00	57	+0.2
220BX-RVC	1.25	61	0
250BX-RVC	1.75	48	+0.3
350BX-RVC	2.50	43	0
440BX-RVC	2.00	78	0
520BX-RVC	2.00	83	0

● 标准中心齿轮 Standard Center Gear

RVC型减速器备有标准中心齿轮。如果需要标准中心齿轮，请在订购时指定。表D.7为标准中心齿轮大齿轮的齿轮参数。

RVC type gear reducer with standard center gear. If you need a standard center gear, please specify when ordering. Table D.7 gear parameters of the standard center gear.

● 表D.7: 标准中心齿轮大齿轮的齿轮参数

Table D.7: Gear parameters of standard center gear

机型 Model	齿轮模数 Gear Modulus m	齿轮 Gear z	变位系数 Coefficient Of Variation x
150BX-RVC	2.00	57	0
180BX-RVC	1.25	78	0
220BX-RVC	2.00	78	0
250BX-RVC	1.75	112	0
350BX-RVC	2.00	110	0
440BX-RVC	2.00	125	0
520BX-RVC	2.00	150	0

■ 润滑 lubrication

- 减速器在出厂时未填充润滑脂，因此在安装减速器时，请务必根据所需填充量填充建议的润滑剂。

Reducer in the factory is not filled with grease, so in the installation of the reducer, be sure to fill according to the required amount of filling the recommended lubricant.

- 减速器的润滑剂填充量一般占内部空间的70-90%，请确保有10%左右的空间未注满。

Reducer lubricant filling amount accounts for the interior space of the 70-90%, please make sure that there are about 10% of the space is not filled up.

- 减速器安装设计时请注意需要二个注油孔，需要密封及方便加注油脂，排出油脂。

Please note that the design of reducer installation needs two oil filling hole, need to seal and convenient oil filling, discharge of oil.

- 减速器封入油脂后，一般更换油脂时间为5000小时左右，请定期检查润滑脂的老化、污染情况，并规定更换时间。

Reducer sealed grease, the general replacement of oil time is about 5000 hours, please regularly check the grease of aging, pollution, and the provisions of replacement time.

● 图 D.6: 润滑油注入位置(水平)

Figure D.6: Lubricating oil injection position (horizontal)
(安装水平轴 Install horizontal axis)

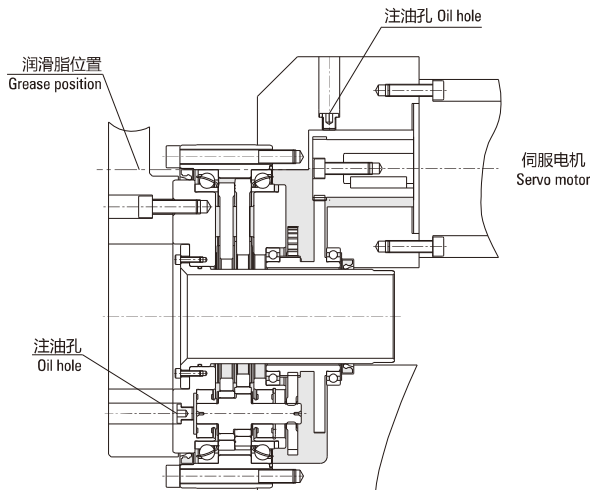

■ 螺栓的紧固转扭 Tightening Torque Of Bolts

RVC型减速器使用内六角螺栓，请按表C.4的紧固转扭进行紧固，螺栓请使用碟形弹簧垫圈，防止螺栓松动及擦伤螺栓座面。

RVC type reducer using the six angle bolt, according to the table C.4 fastening torque for fastening, bolts, please use the disc spring washer, to prevent bolt loose and scratch the bolt seat.

■ 安装输入齿轮 Install Input Gear

图D.5: 表示伺服电机轴的形状和输入齿轮的安装示例，请参照此图进行设计。

Figure D.5: indicates the shape of the servo motor shaft and the installation of the input gear sample, please refer to this diagram for design.

● 图 D.5: 输入齿轮装配 Figure D.5: Input gear assembly

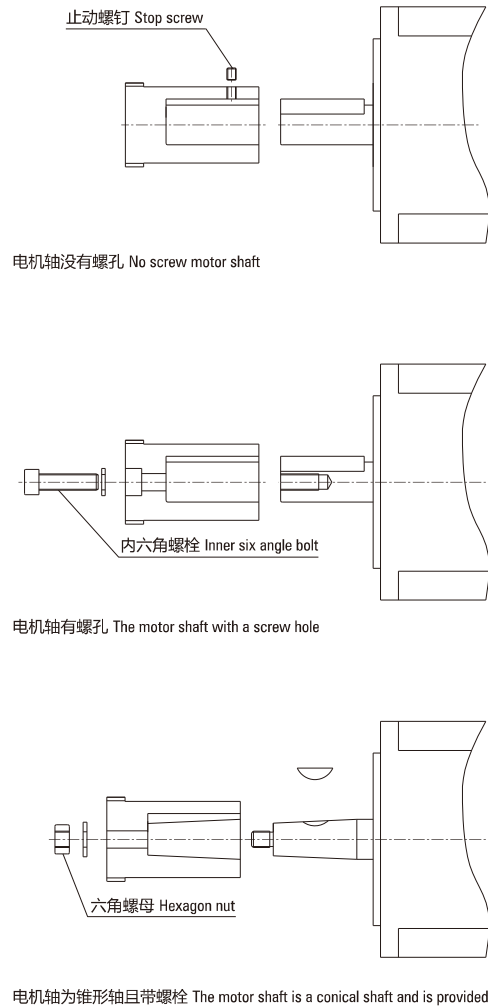

● 图 D.7: 润滑油注入位置(垂直) Figure D.7: Lubricating oil injection position (vertical)

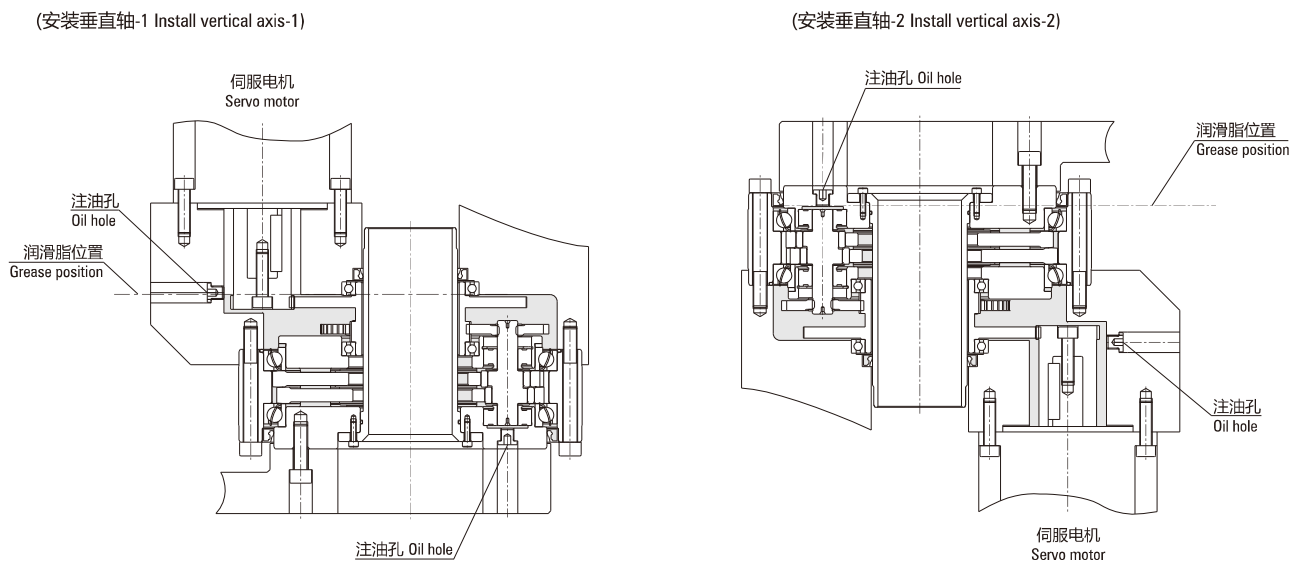

● 表D.8: 润滑脂填充量 Table D.8: Grease filling amount

机型 Model	安装水平轴 (CC) Install Horizontal Axis (CC)	安装垂直轴 (cc) Install Vertical Axis (CC)
150BX-RVC	147	167
180BX-RVC	266	305
220BX-RVC	498	571
250BX-RVC	756	857
350BX-RVC	1831	2076
440BX-RVC	3536	4047
520BX-RVC	5934	6900

■ 保修 Guarantee

保修期及保修范围规定如下。 The warranty period and the scope of the warranty provisions are as follows.

● 保修期 Warranty period

在产品目录中记载的正常组装状态及润滑状态下使用的前提下，保修期为交货后的一年时间或该产品运行时间达到2000小时两者中最先达到的时间。

In the product catalog records of the normal assembly and lubrication under the condition of the use of the premise, the warranty period for the delivery of a year or the product running time of 2000 hours to reach the first time between the two.

● 保修范围 Warranty coverage

在上述保修期内，因本公司产品缺陷导致故障时，由本公司负责对本产品进行维修或更换。

During the warranty period, the company shall be responsible for the maintenance or replacement of the product as a result of the failure of the company's product defects.

但以下情况不在保修范围内。

But the following conditions are not within the scope of the warranty.

- | | |
|---------------------|--|
| ① 因客户不当操作或使用导致故障的 | Failure due to improper operation or use of the customer |
| ② 非本公司实施的改造或修理导致故障的 | Non the company's implementation of the transformation or repair of the failure of the |
| ③ 非本产品原因导致故障的 | Non product causes of failure |
| ④ 其它天灾等非本公司责任导致故障的 | Other natural disasters and other non liability of the company led to the failure of |

而且，这里所说的保修是指对本产品的保修。

Moreover, the warranty here refers to the warranty for this product.

对于因本产品故障引发的其它损失、与设备上拆装相关的工时、费用等，不在本公司负责范围内。

For other losses caused by the failure of this product, and the equipment on the dismantling of the hours, costs, etc., are not responsible for the company.