

安装 ASSEMBLY

■ 安装马达的步骤 Assembly Procedure

客户自行安装伺服马达时，请按以下要领进行安装。伺服马达的尺寸多种多样，除指定的产品外，有些马达可能会无法连接法兰，因为，一定要使用您订货时指定的马达。

If a customer personally assembles the servo motor and reducer please use the following tip. The reducer flange to which the servo motor is attached has different dimensions based on the motor specified. Therefore, assembly may be impossible for some motor. Make sure the correct motor is specified before ordering the reducer.

1. 安装无键马达 Spec. In Case Of Assembling A Motor Without Key

- ① 拧去紧定螺钉，转动输入轴，使螺栓头和紧定螺钉的孔吻合。并确认固定螺栓已松开。
Take off the rubber cap, turn the input shaft, and match the head of the bolt to the hole of the rubber cap. Make sure that the set bolt is loosened.
- ② 将马达轴平稳地插入输出轴（请确保不受阻塞地顺畅的插入）。请充分注意不要让马达倾斜插入。
Gradually put the motor shaft into the input shaft (Ensure that it is smoothly put in without iam.) Be careful not to be inserted with the motor tilted.
- ③ 将马达固定在减速机上，并按指定的扭矩将螺栓拧紧。参考表1
Attach the motor to the reducer and fasten the bolt with designated fastening torque. See Table 1.
- ④ 使用扭矩扳手等工具，按指定的扭矩将输入轴的固定螺栓拧紧。参考表2
Fasten the set bolt of the input shaft with designated fastening torque wrench, etc. See Table 2.
- ⑤ 拧上紧定螺钉。安装到此结束。
Put on a rubber cap. It is the end of assembling.

● 表1 Table1

马达固定螺栓 Motor Combination Bolt	拧紧扭矩 Fastening Torque	
	(N-m)	(kgf-cm)
M3	1.0	10
M4	3.0	30
M5	5.8	60
M6	9.8	100
M8	19.6	200
M10	39.2	400
M12	68.6	700
M16	168	1650

● 表2 Table2

固定螺栓 Combination Bolt	拧紧扭矩 Fastening Torque	
	(N-m)	(kgf-cm)
M3	1.5	15
M4	3.5	35
M5	7.1	71
M6	12	120
M8	30	300
M10	60	612

带键槽式马达的键取下后，可以像上述无键马达一样安装。无需担心会滑动。

You can assemble the motor with keyway like above when take off the key. There is no risk of dislocation.

● ZB/ZE系列示意图
ZB/ZE Series Schematic Diagram

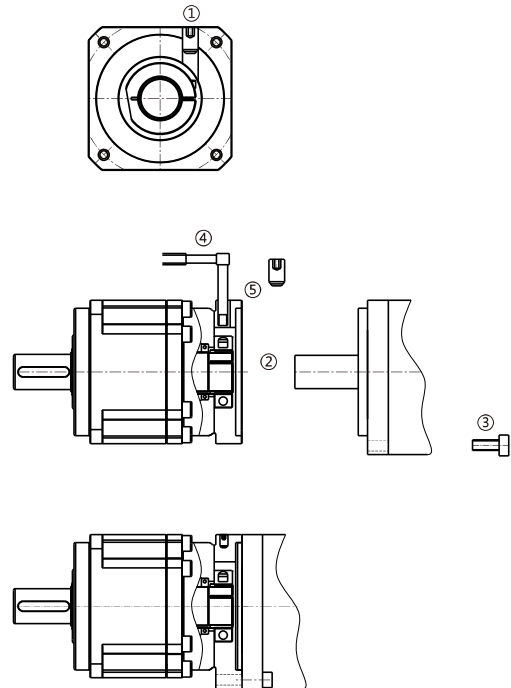

安装 ASSEMBLY

■ 减速机的安装 Reducer Assembly

将减速机安装在设备上时，请在确认安装面平坦且无毛刺等后，使用扭矩扳手等工具按指定的扭矩用螺栓将其固定。参考表4

Jointing with reducer In case of jointing a reducer with the device, make sure that the combining side is plane without inconsistency, and when assemble reducer outo equipment, ensuring assembly surface smooth and without burr. See Table 4.

● 表4 Table4

减速机固定螺栓 Reducer Combination Bolt	拧紧扭矩 Fastening Torque	
	(N·m)	(kgf·cm)
M5	5.8	60
M6	9.8	100
M8	19.6	200
M10	39.2	400
M12	68.6	700
M16	16.8	1650

■ 连接输出轴 Connection To The Output Shaft

注意事项 Cauti ons:

- 1、在输出轴上安装耦合器、滑轮等时，请勿在输出轴上施加过大的轴向负荷。
When assemble a coupling, pulley, etc. onto the output shaft, make sure that excessive axial load not be given to the output shaft.
- 2、请勿使用强力将轴敲入，以免使轴承或减速机内部受到损伤。
In case of strongly hitting the shaft with a hammer, the shaft inlet or the inside of the reducer may be damaged, therefore it shall be prohibited.
- 3、安装的耦合器等的轴和键槽如有较大松动，可能会导致设备烧毁，安装时请充分注意。 If the shaft or key of a coupling assembled is loosed, it may cause carbonization, so be careful when assembling.
- 4、安装耦合器等时，请使用固定螺栓来将键固定住。
For assembling of a coupling, fix the key with a set bolt.
- 5、连接时请充分调校轴心。 Please adjust shaft centre carefully in connecting.

