

ZB系列减速机 ZB SERIES GEAR BOX

剖视图 Sectional Drawing

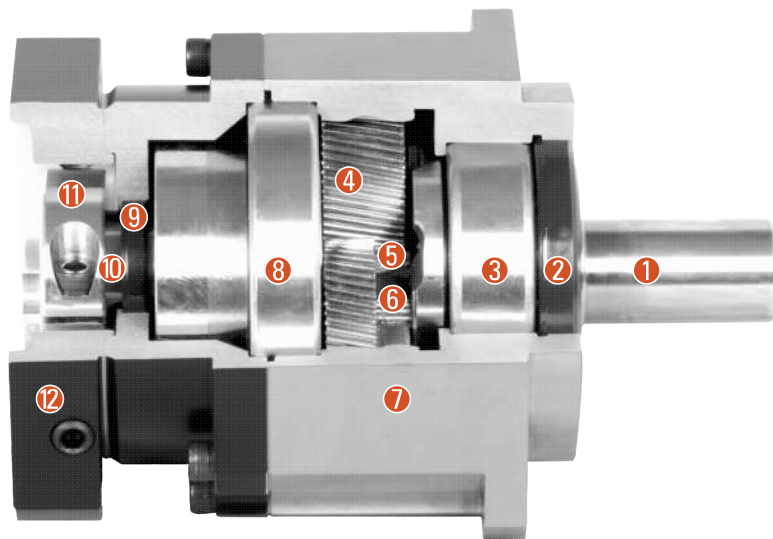

- ① 输出轴 Output shaft
- ② 油封 Oil seal
- ③ 输出轴前轴承 Output shaft front bearing
- ④ 行星轮 Planetary gear
- ⑤ 太阳轮 Solar wheel
- ⑥ 满针轴承 Full needle bearing
- ⑦ 前盖 Front cover
- ⑧ 输出轴后轴承 Output shaft rear bearing
- ⑨ 油封 Oil seal
- ⑩ 联轴器 Coupling
- ⑪ 锁紧环 Lock ring
- ⑫ 后盖 rear cover

系列号、机座标识说明 Type And Model Number

ZB减速机 ZB Reducers	伺服电机 Servo Motor
090 ZB 20 () (S) - 750 T1 	
① ② ③ ④ ⑤ ⑥ ⑦ ⑧	
① 减速机机座号:090 具体见P04	Gear head frame size:090
② 减速机系列代号:ZB	Gear head series code:ZB
③ 减速比:20 具体见P04	Gear Ratio: Single Stage 20,(P04)
④ 精度 具体见P04 标准型P2(省略) 精密型P1 高精度型P0 输出轴负荷量为容许输出扭矩的±5%时的值	Amount of backlash,(P04) Standard type P2 precision P1 high precision P0 precision (the load of output shaft is ±5% of allowable output torque)
⑤ 输入轴型式 S:整体锁紧(省略)(无论马达是否有键槽都可使用,但“D”字型不适用) S1:带锁紧环锁紧(无论马达是否有键槽都可使用,但“D”字型不适用) S2:带键槽锁紧(输入轴带键) K:带键槽 A:其他适配器(请与本公司联系)	Input shaft type S:Over locking(Omission)(regardless whether the motor with keyway can use it.But D Cut can't use) S1:Locking with locking ring(regardless whether the motor with keyway can use it.But D Cut can't use) S2:Locking with keyway (input shaft with key) K:With keyway A:Other type (please contact with us)
⑥ 适用伺服马达功率(W)	Applicable servo motor power (W)
⑦ 伺服马达厂家名称(P11~P12)	Manufacturer name of servo motor (P11~P12)
⑧ 伺服马达型号	Model of servo motor

产品规格 PRODUCT SPECIFICATIONS

■ 减速机性能资料 Reducer Performance Data

规格 Specifications		级数 Node Number	减速比 ¹ Reduction Ratio	060ZB	060(A)ZB	090ZB	090(A)ZB	115ZB	142ZB	180ZB	220ZB
额定输出力矩 T_{2B}	Nm	1	3	55	-	130	-	208	342	588	1140
			4	50	-	140	-	290	542	1050	1700
			5	60	-	160	-	330	650	1200	2000
			6	55	-	150	-	310	600	1100	1900
			7	50	-	140	-	300	550	1100	1800
			8	45	-	120	-	260	500	1000	1600
			9	40	-	100	-	230	450	900	1500
			10	40	-	100	-	230	450	900	1500
			15	55	55	130	130	208	342	588	1140
		20	50	50	140	140	290	542	1050	1700	
		25	60	60	160	160	330	650	1200	2000	
		30	55	55	150	150	310	600	1100	1900	
		35	50	50	140	140	300	550	1100	1800	
		40	45	45	120	120	260	500	1000	1600	
		45	40	40	100	100	230	450	900	1500	
		50	60	60	160	160	330	650	1200	2000	
		60	55	55	150	150	310	600	1100	1900	
		70	50	50	140	140	300	550	1100	1800	
		80	45	45	120	120	260	500	1000	1600	
90	40	40	100	100	230	450	900	1500			
100	40	40	100	100	230	450	900	1500			
急停扭矩 T_{2B01} ²	Nm	1,2	3~100	3倍额定输出力矩							
额定输入转速 n_{1n}	rpm	1,2	3~100	5000	5000	4000	4000	4000	3000	3000	2000
最大输入转速 n_{1a}	rpm	1,2	3~100	10000	10000	8000	8000	8000	6000	6000	4000
超精密回程精度 P0	arcmin	1	3~10	-	-	-	-	≤1	≤1	≤1	≤1
		2	15~100	-	-	-	-	≤3	≤3	≤3	≤3
精密回程精度 P1	arcmin	1	3~10	≤3	-	≤3	-	≤3	≤3	≤3	≤3
		2	15~100	-	≤5	≤5	≤5	≤5	≤5	≤5	≤5
标准回程精度 P2	arcmin	1	3~10	≤5	-	≤5	-	≤5	≤5	≤5	≤5
		2	15~100	-	≤7	≤7	≤7	≤7	≤7	≤7	≤7
扭转刚性	Nm/arcmin	1,2	3~100	7	7	14	14	25	50	145	225
容许径向力 F_{2B}^3	N	1,2	3~100	1530	1530	3250	3250	6700	9400	14500	50000
容许轴向力 F_{2B}^3	N	1,2	3~100	765	765	1625	1625	3350	4700	7250	25000
使用寿命	hr	1,2	3~100	20000*							
效率 η	%	1	3~10	≥97%							
		2	15~100	≥94%							
重量	Kg	1	3~10	1.3	-	3.7	-	7.8	14.5	29	48
		2	15~100	1.5	1.9	4.1	5.3	9	17.5	33	60
使用温度	°C	1,2	3~100	-10°C~+90°C							
润滑		1,2	3~100	合成润滑油脂							
防护等级		1,2	3~100	IP65							
安装方向		1,2	3~100	任意方向							
噪音值 距离1m ($n_1=3000\text{rpm}$, 无负载)	dB(A)	1,2	3~100	≤58	≤60	≤60	≤63	≤63	≤65	≤67	≤70

■ 减速机转动惯量 Moment Of Inertia Of The Reducer

规格 Specifications		级数 Node Number	减速比 Reduction Ratio	060ZB	060(A)ZB	090ZB	090(A)ZB	115ZB	142ZB	180ZB	220ZB
转动惯量 J_1	Kg·cm ²	1	3	0.16	-	0.61	-	3.25	9.21	28.98	69.61
			4	0.14	-	0.48	-	2.74	7.54	23.67	54.37
			5	0.13	-	0.47	-	2.71	7.42	23.29	53.27
			6	0.13	-	0.45	-	2.65	7.25	22.75	51.72
			7	0.13	-	0.45	-	2.62	7.14	22.48	50.97
			8	0.13	-	0.44	-	2.58	7.07	22.59	50.84
			9	0.13	-	0.44	-	2.57	7.04	22.53	50.63
			10	0.13	-	0.44	-	2.57	7.03	22.51	50.56
			15	0.03	0.13	0.13	0.47	0.47	2.71	7.42	23.29
		20	0.03	0.13	0.13	0.47	0.47	2.71	7.42	23.29	
		25	0.03	0.13	0.13	0.47	0.47	2.71	7.42	23.29	
		30	0.03	0.13	0.13	0.47	0.47	2.71	7.42	23.29	
		35	0.03	0.13	0.13	0.47	0.47	2.71	7.42	23.29	
		40	0.03	0.13	0.13	0.47	0.47	2.71	7.42	23.29	
		45	0.03	0.13	0.13	0.47	0.47	2.71	7.42	23.29	
		50	0.03	0.13	0.13	0.44	0.44	2.57	7.03	22.51	
		60	0.03	0.13	0.13	0.44	0.44	2.57	7.03	22.51	
		70	0.03	0.13	0.13	0.44	0.44	2.57	7.03	22.51	
		80	0.03	0.13	0.13	0.44	0.44	2.57	7.03	22.51	
90	0.03	0.13	0.13	0.44	0.44	2.57	7.03	22.51			
100	0.03	0.13	0.13	0.44	0.44	2.57	7.03	22.51			

1. 减速比 ($i=N_{1n}/N_{out}$)2. 最大加速力矩 $T_{2B}=60\%$ of T_{2B01}

3. 输出转速100rpm时, 作用于输出轴中心位置。

*连续运转, 使用寿命为10000hrs

尺寸(单级, 减速比 $i=3\sim 10$)

DIMENSIONS(SINGLE SEGMENT, REDUCTION RATIO $i=3\sim 10$)

尺寸图 Dimensional Drawing

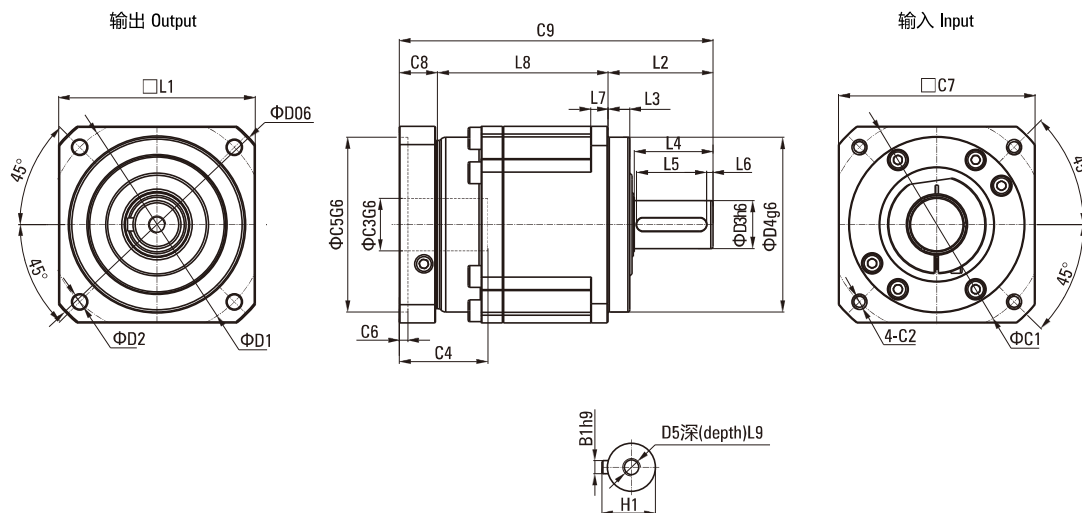

尺寸表 Dimensional Table

[单位:mm]

尺寸Size	060ZB	090ZB	115ZB	142ZB	180ZB	220ZB
D1	70	100	130	165	215	250
D2	5.5	6.6	9	11	13	17
D3 [※]	16	22	32	40	55	75
D4 [※]	50	80	110	130	160	180
D5	M5×0.8P	M8×1.25P	M12×1.75P	M16×2P	M20×2.5P	M20×2.5P
D6	80	116	152	185	240	292
L1	60	90	115	142	180	220
L2	37	48	65	97	105	138
L3	7	10	12	15	20	30
L4	28	36	51	79	82	105
L5	25	32	40	70	70	90
L6	2	3	5	4	6	7
L7	6	8	10	15	20	25
L8	65.5	78	101.5	119.5	154	163.5
L9	12.5	19	28	36	42	42
C1	70	100	130	165	215	235
C2	M5×0.8P	M6×1P	M8×1.25P	M10×1.5P	M12×1.75P	M12×1.75P
C3	*≤14/≤16	≤19/≤24	≤32	≤38	≤48	≤55
C4	35	40.5	51	60	85	116
C5 [※]	50	80	110	130	180	200
C6	8	4	5	6	6	6
C7	60	90	115	142	190	220
C8	19.5	17.5	20	22.5	29	63
C9	122	143.5	186.5	239	288	364.5
B1 ^{h9}	5	6	10	12	16	20
H1	18	24.5	35	43	59	79.5

*060ZB 5,10 减速比提供C3≤16可选。

尺寸(两级, 减速比 $i=15\sim 100$)

DIMENSIONS(DOUBLE, REDUCTION RATIO $i=15\sim 100$)

尺寸图 Dimensional Drawing

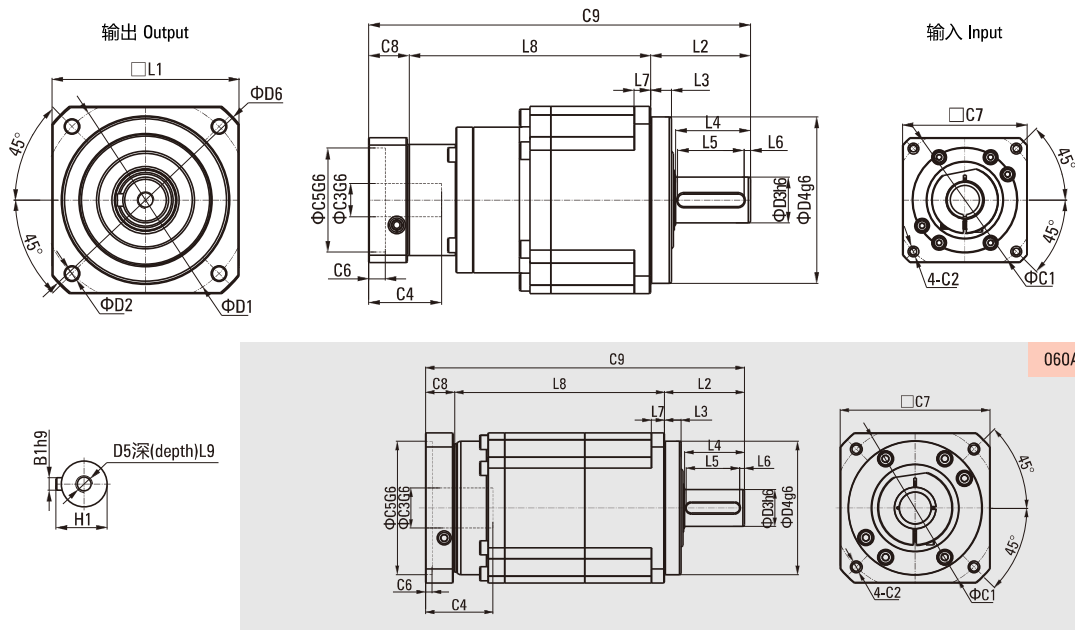

尺寸表 Dimensional Table

[单位:mm]

尺寸Size	060AZB	090ZB	090AZB	115ZB	142ZB	180ZB	220ZB
D1	70	100	130	165	215	250	
D2	5.5	6.6	9	11	13	17	
D3 _{h6}	16	22	32	40	55	75	
D4 _{g6}	50	80	110	130	160	180	
D5	M5×0.8P	M8×1.25P	M12×1.75P	M16×2P	M20×2.5P	M20×2.5P	
D6	80	116	152	185	240	292	
L1	60	90	115	142	180	220	
L2	37	48	65	97	105	138	
L3	7	10	12	15	20	30	
L4	28	36	51	79	82	105	
L5	25	32	40	70	70	90	
L6	2	3	5	4	6	7	
L7	6	8	10	15	20	25	
L8	102.5	116	126	143	169.5	207.5	246
L9	12.5	19	28	36	42	42	
C1	70	70	100	100	130	165	215
C2	M5×0.8P	M5×0.8P	M6×1P	M6×1P	M8×1.25P	M10×1.5P	M12×1.75P
C3	≤14/≤16	≤14/≤15.875/≤16	≤19/≤24	≤19/≤24	≤32	≤38	≤48
C4	35	35	40.5	40	50	60	85
C5 _{g6}	50	50	80	80	110	130	180
C6	8	8	4	4	5	6	6
C7	60	60	90	90	115	142	190
C8	19.5	19.5	17.5	17.5	12.5	22.5	29
C9	159	183.5	191.5	225.5	283.5	335	409
B1 _{h9}	5	6	10	12	16	20	
H1	18	24.5	35	43	59	79.5	