

ZDS 3000W 尺寸图与性能表

ZDS 3000W DIMENSIONAL DRAWING & PERFORMANCE TABLE

■ 性能表 Performance Table (输入转速为3,000rpm时 When Input Speed Is 3000rpm)

额定输入 马达功率 Rated Input Motor	减速比 Reduction Ratio	型号 Model				输出轴 转速 Outout Shaft Speed (rpm)	额定输出 扭矩 Standard Output Torque (N.m)	瞬间最大 输出扭矩 Instantaneous Max.Output Torque (N.m)	容许径向 负荷 Permissible Radial Load (N)	容许轴向 负荷 Permissible Axial Load (N)	输入轴换算 内部惯性力矩 Internal Moment Of inertia Of Input Shaftconversion ($\times 10^{-3}$ kg.m ²)	容许输出 扭矩 Permissible Output Torque (N.m)	瞬间最大容 许输出扭矩 Instantaneous max. Permissible Output Toque (N.m)
		机座号 Type No.	系列号 Model	减速比 Reduction Ratio	马达功率 Motor								
3000W	1/3	90	ZDS	3	-3000	1000	27.51	82.53	9000	4500	0.81	75	150
	1/4	90	ZDS	4	-3000	750	36.68	110.04	9000	4500	0.6	100	200
	1/5	90	ZDS	5	-3000	600	45.85	137.55	9000	4500	0.52	110	220
	1/8	115	ZDS	8	-3000	375	73.35	220.05	12000	6000	1.05	148	296
	1/10	142	ZDS	10	-3000	300	91.69	275.07	19000	9500	4.25	305	610
	1/12	115	ZDS	12	-3000	250	107.73	323.20	12000	6000	2	210	420
	1/15	115	ZDS	15	-3000	200	134.67	404.00	12000	6000	2	210	420
	1/16	115	ZDS	16	-3000	187.5	143.64	430.93	12000	6000	1.48	260	520
	1/20	142	ZDS	20	-3000	150	179.55	538.65	19000	9500	6.65	910	1820
	1/25	142	ZDS	25	-3000	120	224.44	673.31	19000	9500	5.81	780	1560
	1/32	142	ZDS	32	-3000	93.75	287.27	861.82	19000	9500	5.36	910	1820
	1/40	142	ZDS	40	-3000	75	359.09	1077.27	19000	9500	5.28	780	1560
	1/64	190	ZDS	64	-3000	46.875	574.54	1723.61	28000	14000	16.45	1000	2000

注1) 安装基准系列(马达适用表记载系列)以外的马达时, 每次都是与我们联系。(法兰尺寸可能不同)

注2) 输入轴换算惯性力矩仅为减速机的数值, 不包括马达的惯性力矩。

注3) 最高输入转速为5000rpm。正常情况下请转速控制在3000rpm以下。

注4) 容许径向负荷表示输出轴中央部位的值。

注5) 马达的安装顺序请参照P.158。

注6) 输出轴旋转方向与马达输入旋转方向相同。

Note1) In case of attachment to a motor beyond the standard models(motor matching series), contact us. (How to measure dimensions of the flange may be changed in some cases.)

Note2) The moment of inertia of input shaft conversion is only gained from the reducer, so it does not include moment of inertia of the motor.

Note3) The max. input speed is 5000rpm, and usually set to 3000rpm or less.

Note4) The permissible radial load is indicated on the center of the output shaft.

Note5) For motor assembly procedure, see 158 page.

Note6) Rotation of the output shaft is in the same direction as motor.

P144

■ 尺寸图 Dimensional Drawing

● 90ZDS3-4-5-3000

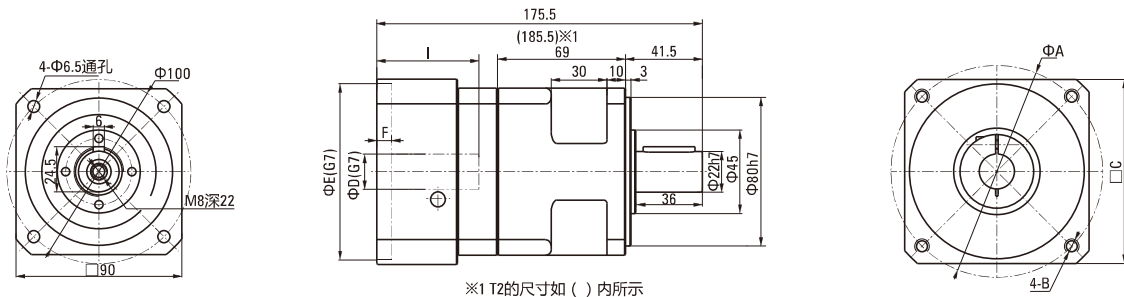

● 法兰部位详细尺寸表 Detailed Flange Dimensions Table

(单位Unit:mm)

马达种类 Motor Type	A	B	C	D	E	F	I
T1	130	M8深(depth)20	120	22	110	8	55
T2	145	M8深(depth)20	130	28	110	8	65
T3	-	-	-	-	-	-	-

● T1~3的详细情况请参照P.156

For details of T1~3, see 156 page

ZDS 3000W 尺寸图与性能表

ZDS 3000W DIMENSIONAL DRAWING & PERFORMANCE TABLE

尺寸图 Dimensional Drawing

● 115ZDS8-3000

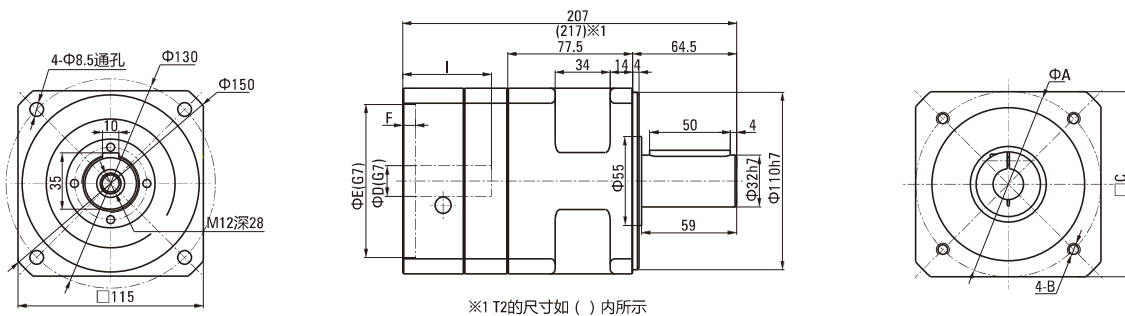

※1 T2的尺寸如 () 内所示

● 115ZDS12-15-16-3000

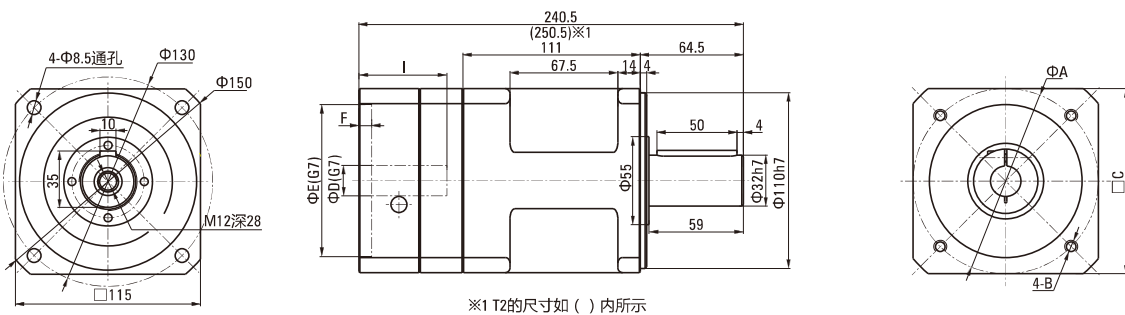

※1 T2的尺寸如 () 内所示

● 142ZDS10-3000

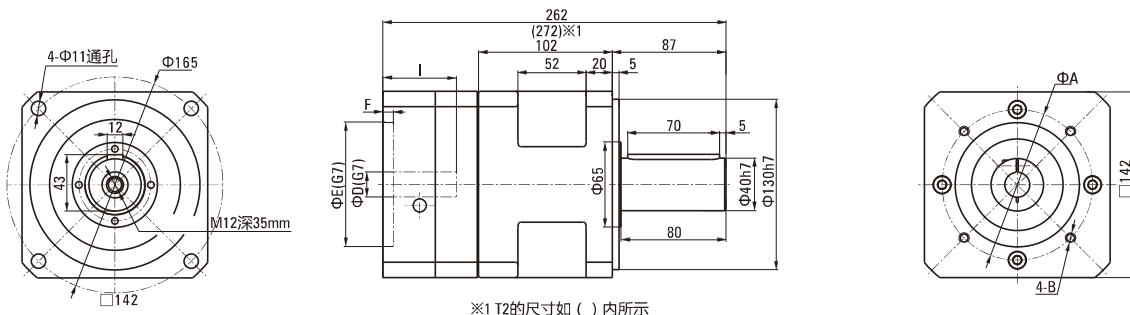

※1 T2的尺寸如 () 内所示

● 法兰部位详细尺寸表 Detailed Flange Dimensions Table (单位Unit:mm)

马达种类 Motor Type	A	B	C	D	E	F	I
T1	130	M8深(depth)20	120	22	110	8	55
T2	145	M8深(depth)20	130	28	110	8	65
T3	-	-	-	-	-	-	-

• T1~3的详细情况请参照P156
For details of T1~3, see 156 page

ZDS 3000W 尺寸图与性能表

ZDS 3000W DIMENSIONAL DRAWING & PERFORMANCE TABLE

尺寸图 Dimensional Drawing

● 142ZDS20-25-32-40-3000

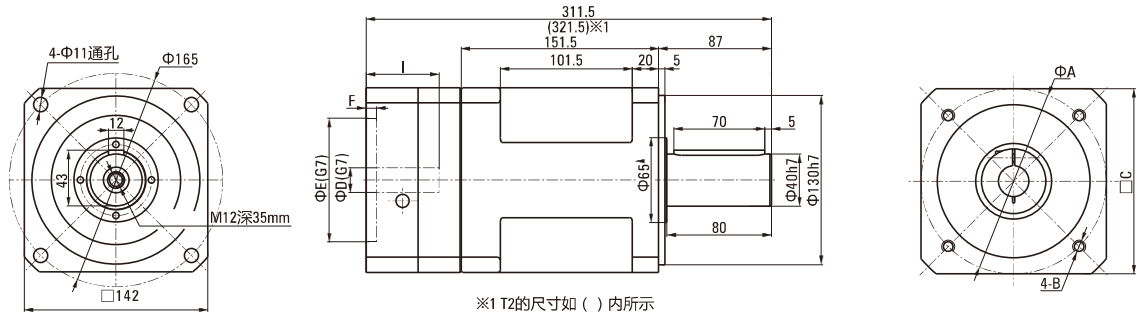

● 190ZDS64-3000

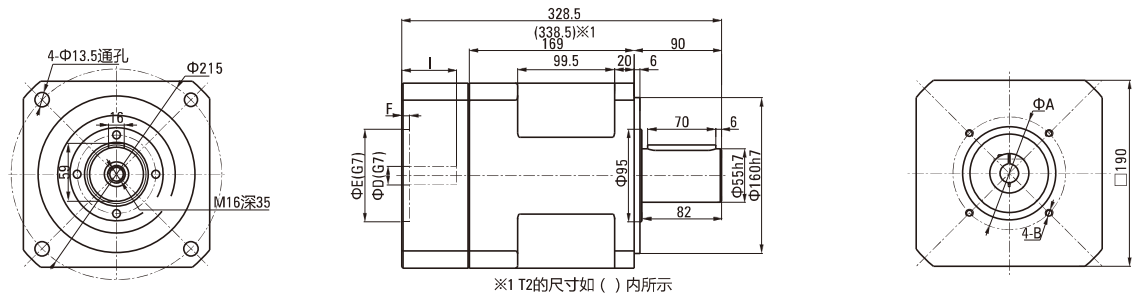

● 法兰部位详细尺寸表 Detailed Flange Dimensions Table (单位Unit:mm)

马达种类 Motor Type	A	B	C	D	E	F	I
T1	130	M8深(depth)20	120	22	110	8	55
T2	145	M8深(depth)20	130	28	110	8	65
T3	-	-	-	-	-	-	-

• T1~3的详细情况请参照P.156
For details of T1~3, see 156 page