

ZDS 1500W 尺寸图与性能表

ZDS 1500W DIMENSIONAL DRAWING & PERFORMANCE TABLE

性能表 Performance Table (输入转速为3,000rpm时 When Input Speed Is 3000rpm)

额定输入 马达功率 Rated Input Motor	减速比 Reduction Ratio	型号 Model				输出轴 转速 Outout Shaft Speed (rpm)	额定输出 扭矩 Standard Output Torque (N.m)	瞬间最大 输出扭矩 Instantaneous Max.Output Torque (N.m)	容许径向 负荷 Permissible Radial Load (N)	容许轴向 负荷 Permissible Axial Load (N)	输入轴换算 内部惯性力矩 Of Input Shaftconversion Internal Moment Ofinertia ($\times 10^{-4}$ kg.m ²)	容许输出 扭矩 Permissible Output Torque (N.m)	瞬间最大容 许输出扭矩 Instantaneous max. Permissible Output Toque (N.m)
		机座号 Type No.	系列号 Model	减速比 Reduction Ratio	马达功率 Motor								
1500W	1/3	70	ZDS	3	-1500	1000	13.74	41.22	9000	4500	0.32	30	60
	1/4	70	ZDS	4	-1500	750	18.32	54.96	6000	3000	0.2	40	80
	1/5	70	ZDS	5	-1500	600	22.90	68.70	6000	3000	0.16	50	100
	1/8	90	ZDS	8	-1500	375	36.64	109.92	9000	4500	0.46	62	154
	1/10	115	ZDS	10	-1500	300	45.80	137.40	12000	6000	1	125	250
	1/12	90	ZDS	12	-1500	250	53.82	161.45	9000	4500	0.75	110	220
	1/15	90	ZDS	15	-1500	200	67.27	200.00	9000	4500	0.74	110	220
	1/16	90	ZDS	16	-1500	187.5	71.75	245.25	9000	4500	0.56	120	240
	1/20	115	ZDS	20	-1500	150	89.69	269.06	12000	6000	1.41	260	520
	1/25	115	ZDS	25	-1500	120	112.11	336.32	12000	6000	1.21	210	420
	1/32	115	ZDS	32	-1500	93.75	143.49	430.47	12000	6000	1.05	260	520
	1/40	142	ZDS	40	-1500	75	179.36	538.09	19000	9500	5.28	780	1560
1/64	142	ZDS	64	-1500	46.875	286.97	860.92	19000	9500	4.5	450	900	

注1) 安装基准系列(马达适用表记载系列)以外的马达时, 每次都是与我们联系。(法兰尺寸可能不同)

注2) 输入轴换算惯性力矩仅为减速机的数值, 不包括马达的惯性力矩。

注3) 最高输入转速为5000rpm。正常情况下请转速控制在3000rpm以下。

注4) 容许径向负荷表示输出轴中央部位的值。

注5) 马达的安装顺序请参照P.158。

注6) 输出轴旋转方向与马达输入旋转方向相同。

Note1) In case of attachment to a motor beyond the standard models(motor matching series), contact us. (How to measure dimensions of the flange may be changed in some cases.)

Note2) The moment of inertia of input shaft conversion is only gained from the reducer, so it does not include moment of inertia of the motor.

Note3) The max. input speed is 5000rpm, and usually set to 3000rpm or less.

Note4) The permissible radial load is indicated on the center of the output shaft.

Note5) For motor assembly procedure, see 158 page.

Note6) Rotation of the output shaft is in the same direction as motor.

尺寸图 Dimensional Drawing

● 70ZDS3-4-5-1500

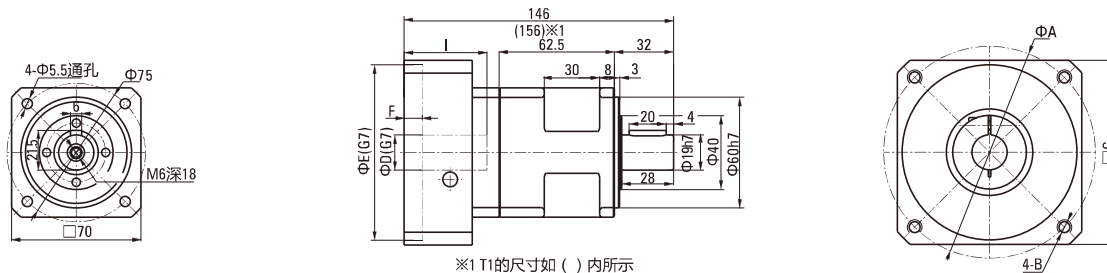

● 法兰部位详细尺寸表 Detailed Flange Dimensions Table

(单位Unit:mm)

马达种类 Motor Type	A	B	C	D	E	F	I
T1	115	M8深(depth)20	100	19	95	5	55
T2	115	M6深(depth)15	100	24	95	5	45
T3	115	M8深(depth)20	100	24	95	5	45

• T1~3的详细情况请参照P.156

For details of T1~3, see 156 page

ZDS 1500W 尺寸图与性能表

ZDS 1500W DIMENSIONAL DRAWING & PERFORMANCE TABLE

尺寸图 Dimensional Drawing

● 90ZDS8-1500

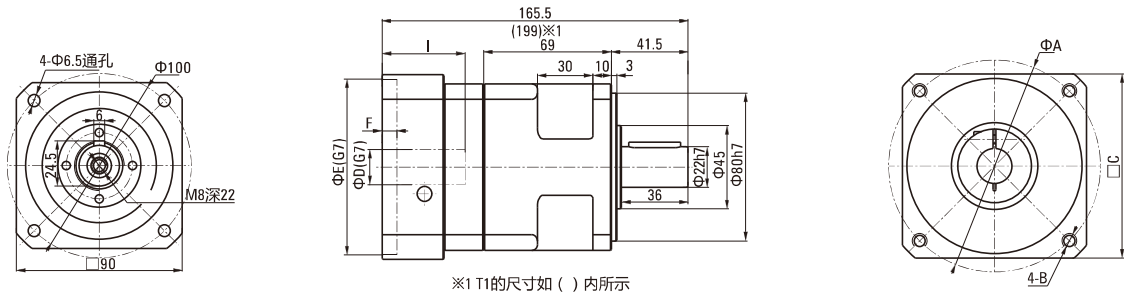

※T1的尺寸如()内所示

● 90ZDS12-15-16-1500

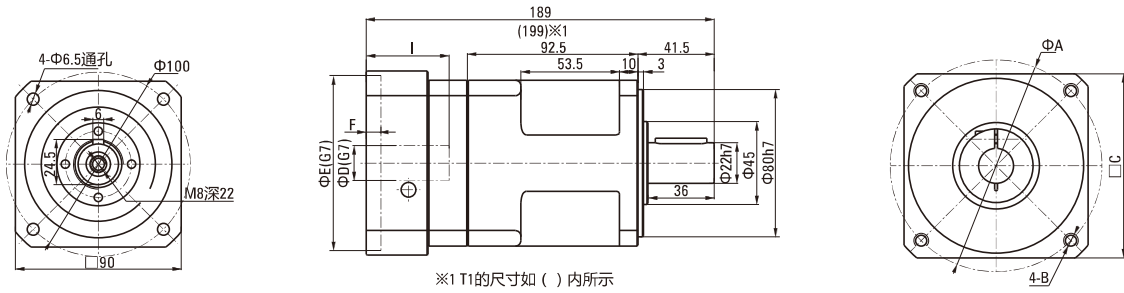

※T1的尺寸如()内所示

● 115ZDS10-1500

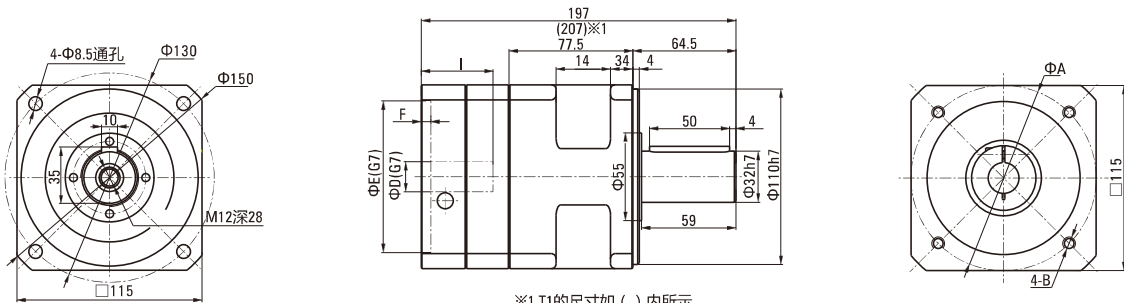

※T1的尺寸如()内所示

● 法兰部位详细尺寸表 Detailed Flange Dimensions Table

(单位Unit:mm)

马达种类 Motor Type	A	B	C	D	E	F	I
T1	115	M8深(depth)20	100	19	95	5	55
T2	115	M6深(depth)15	100	24	95	5	45
T3	115	M8深(depth)20	100	24	95	5	45

• T1~3的详细情况请参照P.156

For details of T1~3, see 156 page

ZDS 1500W 尺寸图与性能表

ZDS 1500W DIMENSIONAL DRAWING & PERFORMANCE TABLE

尺寸图 Dimensional Drawing

● 115ZDS20-25-32-1500

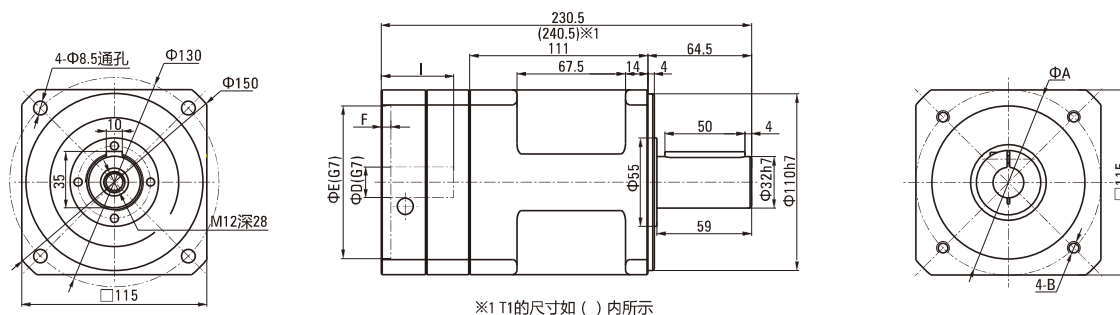

● 142ZDS40-60-1500

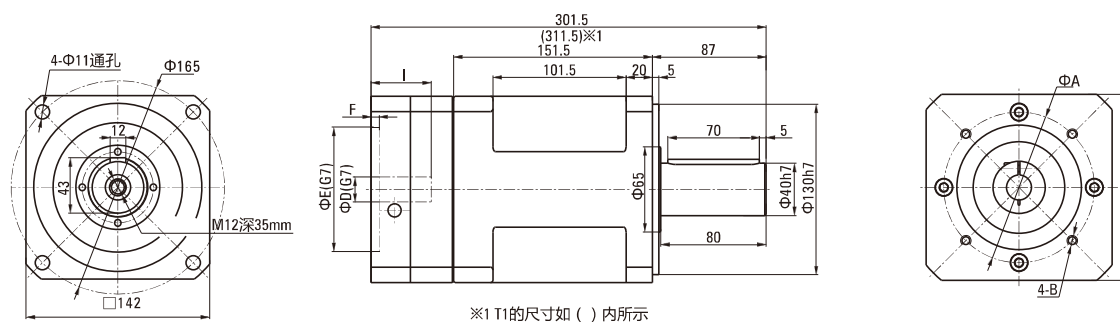

● 法兰部位详细尺寸表 Detailed Flange Dimensions Table (单位Unit:mm)

马达种类 Motor Type	A	B	C	D	E	F	I
T1	115	M8深(depth)20	100	19	95	5	55
T2	115	M6深(depth)15	100	24	95	5	45
T3	115	M8深(depth)20	100	24	95	5	45

• T1~3的详细情况请参照P156

For details of T1~3, see 156 page