

ZDWE/ZDWF 4000W 尺寸图与性能表

ZDWE/ZDWF 4000W DIMENSIONAL DRAWING & PERFORMANCE TABLE

性能表 Performance Table (输入转速为3,000rpm时 When Input Speed Is 3000rpm)

额定输入 马达功率 Rated Input Motor	减速比 Reduction Ratio	型号 Model				输出轴 转速 Outout Standard Shaft Speed	额定输出 扭矩 Output Torque	瞬间最大 输出扭矩 Instantaneous Max.Output Torque	容许径向 负荷 Permissible Radial Load	容许轴向 负荷 Permissible Axial Load	输入轴换算 内部惯性力矩 Internal Moment Ofinertia Of Input Shaftconversion	容许输出 扭矩 Permissible Output Torque	瞬间最大容 许输出扭矩 Instantaneous max. Permissible Output Toque
		机座号 Type No.	系列号 Model	减速比 Reduction Ratio	马达功率 Motor								
4000W	1/3	120	ZDW□	3	-4000	1000	36.58	109.74	2100	1050	5.75	80	160
	1/4	120	ZDW□	4	-4000	750	48.77	146.31	2100	1050	3.91	110	220
	1/5	120	ZDW□	5	-4000	600	60.97	182.91	2100	1050	3.35	110	220
	1/9	120	ZDW□	9	-4000	333.3	107.45	322.36	6000	3000	5.73	210	420

注1) 安装基准系列(马达适用表记载系列)以外的马达时, 每次都是与
我们联系。(法兰尺寸可能不同)
注2) 输入轴换算惯性力矩仅为减速机的数值, 不包括马达的惯性力矩。
注3) 最高输入转速为5000rpm。正常情况下请转速控制在3000rpm以下。
注4) 容许径向负荷表示输出轴中央部位的值。
注5) 马达的安装顺序请参考P158。
注6) 输出轴旋转方向与马达输入旋转方向相同。

Note1) In case of attachment to a motor beyond the standard models(motor matching series),
contact us. (How to measure dimensions of the flange may be changed in some cases.)
Note2) The moment of inertia of input shaft conversion is only gained from the reducer, so it
does not include moment of inertia of the motor.
Note3) The max. input speed is 5000rpm, and usually set to 3000rpm or less.
Note4) The permissible radial load is indicated on the center of the output shaft.
Note5) For motor assembly procedure, see 158 page.
Note6) Rotation of the output shaft is in the same direction as motor.

ZDWE尺寸图 Dimensional Drawing

120ZDWE3-4-5-4000

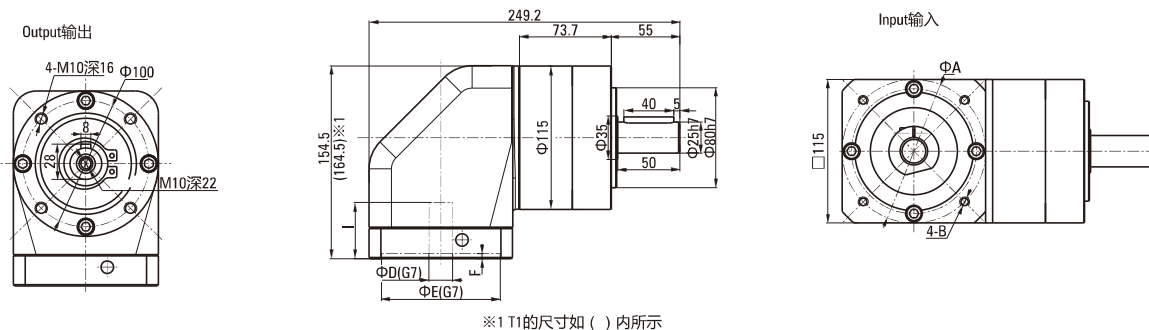

120ZDWE9-4000

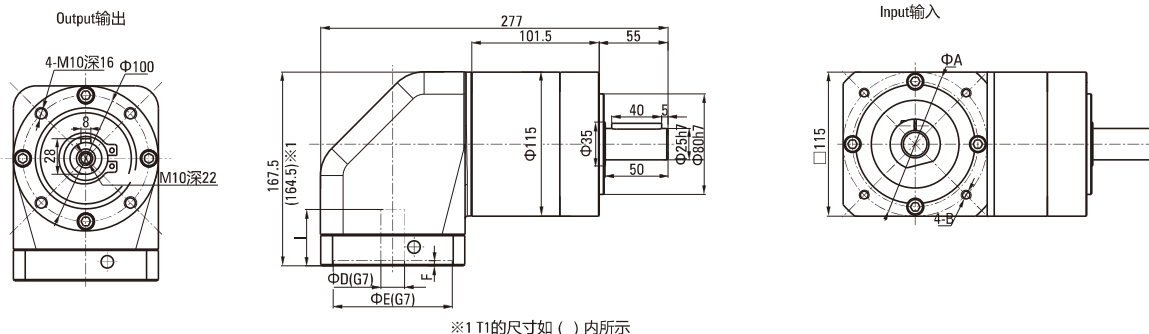

法兰部位详细尺寸表 Detailed Flange Dimensions Table

(单位Unit:mm)

马达种类 Motor Type	A	B	C	D	E	F	I
T1	145	M8深(depth)20	130	24	110	8	65
T2	145	M8深(depth)20	130	28	110	8	65
T3	-	-	-	-	-	-	-

• T1~3的详细情况请参考P156
For details of T1~3, see 156 page

ZDWE/ZDWF 4000W 尺寸图与性能表

ZDWE/ZDWF 4000W DIMENSIONAL DRAWING & PERFORMANCE TABLE

ZDWF 尺寸图 Dimensional Drawing

● 120ZDWF3-4-5-4000

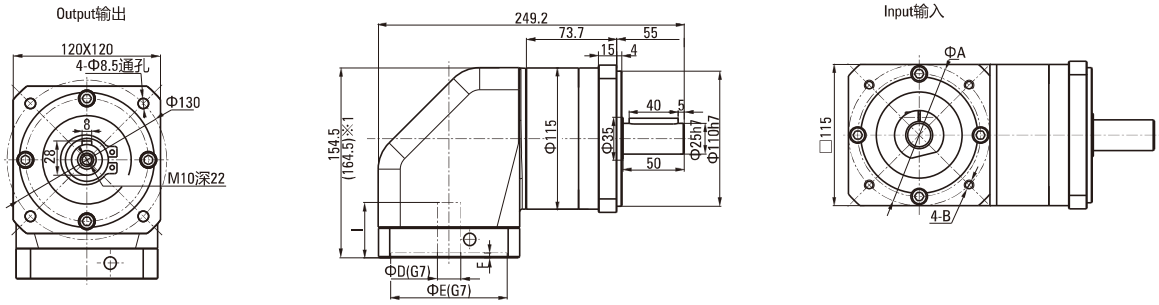

※1 T1 的尺寸如 () 内所示

● 120ZDWF9-4000

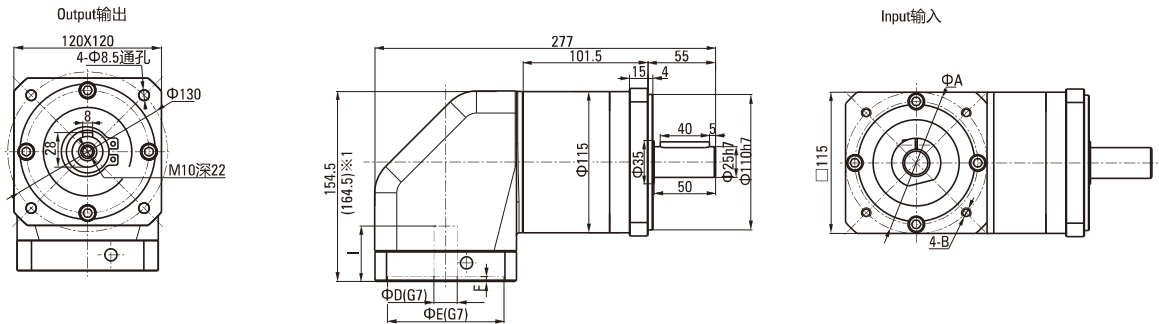

※1 T1 的尺寸如 () 内所示

● 法兰部位详细尺寸表 Detailed Flange Dimensions Table (单位Unit:mm)

马达种类 Motor Type	A	B	C	D	E	F	I
T1	145	M8深(depth)20	130	24	110	8	65
T2	145	M8深(depth)20	130	28	110	8	65
T3	-	-	-	-	-	-	-

• T1~3的详细情况请参照P.156
For details of T1~3, see 156 page