

# ZDE/ZDF 2500W 尺寸图与性能表

## ZDE/ZDF 2500W DIMENSIONAL DRAWING & PERFORMANCE TABLE

### 性能表 Performance Table (输入转速为3,000rpm时 When Input Speed Is 3000rpm)

额定输入 马达功率 Rated Input Motor	减速比 Reduction Ratio	型号 Model				输出轴 转速 Outout Shaft Speed (rpm)	额定输出 扭矩 Standard Output Torque (N.m)	瞬间最大 输出扭矩 Instantaneous Max.Output Torque (N.m)	容许径向 负荷 Permissible Radial Load (N)	容许轴向 负荷 Permissible Axial Load (N)	输入轴换算 内部惯性力矩 Internal Moment Of inertia Of Input Shaftconversion (x10 <sup>-3</sup> kg.m <sup>2</sup> )	容许输出 扭矩 Permissible Output Torque (N.m)	瞬间最大容 许输出扭矩 Instantaneous max. Permissible Output Toque (N.m)
		机座号 Type No.	系列号 Model	减速比 Reduction Ratio	马达功率 Motor								
2500W	1/3	80	ZD□	3	-2500	1000	22.93	68.79	900	450	0.77	40	80
	1/4	80	ZD□	4	-2500	750	30.57	91.71	900	450	0.52	50	100
	1/5	120	ZD□	5	-2500	600	38.21	114.63	2100	1050	1.53	110	220
	1/8	120	ZD□	8	-2500	375	61.14	183.42	2100	1050	1.32	100	200
	1/10	160	ZD□	10	-2500	300	76.42	229.26	6000	3000	3.52	305	610
	1/9	80	ZD□	9	-2500	333.3	67.35	200.00	900	450	0.74	100	200
	1/12	120	ZD□	12	-2500	250	89.80	269.40	2100	1050	1.5	210	420
	1/15	120	ZD□	15	-2500	200	112.25	336.74	2100	1050	1.49	210	420
	1/16	120	ZD□	16	-2500	187.5	119.73	359.19	2100	1050	1.5	260	520
	1/20	120	ZD□	20	-2500	150	149.66	448.97	2100	1050	1.49	260	520
	1/25	160	ZD□	25	-2500	120	187.07	561.21	6000	3000	6.65	700	1400
	1/32	160	ZD□	32	-2500	93.75	239.45	718.34	6000	3000	4.5	700	1400
	1/40	160	ZD□	40	-2500	75	299.31	897.92	6000	3000	4.5	700	1400

注1) 安装基准系列(马达适用表记载系列)以外的马达时, 每次都要与我们联系。(法兰尺寸可能不同)

注2) 输入轴换算惯性力矩仅为减速机的数值, 不包括马达的惯性力矩。

注3) 最高输入转速为5000rpm。正常情况下请将转速控制在3000rpm以下。

注4) 容许径向负荷表示输出轴中央部位的值。

注5) 马达的安装顺序请参照P.158。

注6) 输出轴旋转方向与马达输入旋转方向相同。

Note1) In case of attachment to a motor beyond the standard models(motor matching series), contact us. (How to measure dimensions of the flange may be changed in some cases.)

Note2) The moment of inertia of input shaft conversion is only gained from the reducer, so it does not include moment of inertia of the motor.

Note3) The max. input speed is 5000rpm, and usually set to 3000rpm or less.

Note4) The permissible radial load is indicated on the center of the output shaft.

Note5) For motor assembly procedure, see 158 page.

Note6) Rotation of the output shaft is in the same direction as motor.

### ZDE尺寸图 Dimension Drawing

● 80ZDE3-4-2500

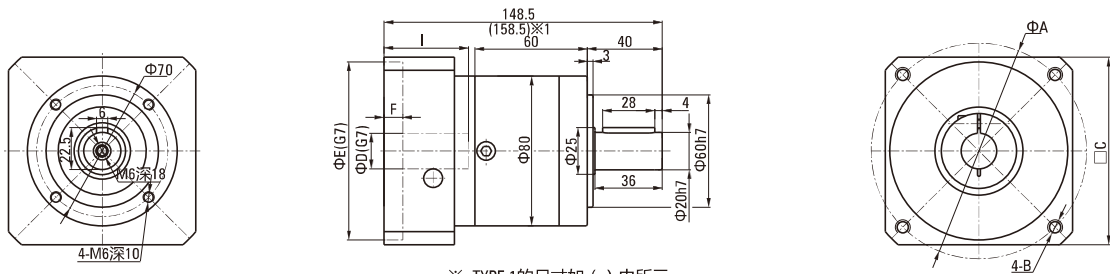

※1 TYPE 1的尺寸如( )内所示

#### 法兰部位详细尺寸表 Detailed Flange Dimensions Table

(单位Unit:mm)

马达种类 Motor Type	A	B	C	D	E	F	I
T1	115	M8深(depth)20	100	19	95	5	55
T2	115	M6深(depth)15	100	24	95	5	45
T3	-	-	-	-	-	-	-

• T1~3的详细情况请参照P.156

• For details of T1~3, see 156 page

# ZDE/ZDF 2500W 尺寸图与性能表

## ZDE/ZDF 2500W DIMENSIONAL DRAWING & PERFORMANCE TABLE

### ZDE尺寸图 Dimensional Drawing

● 80ZDE9-2500

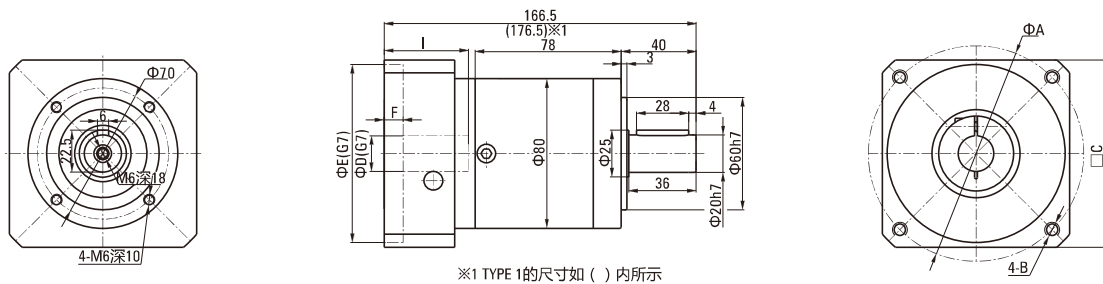

● 120ZDE5-8-2500

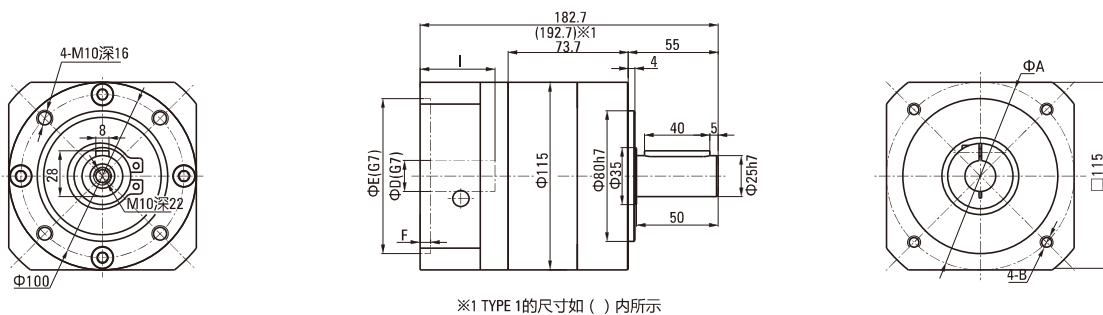

● 120ZDE12-15-16-20-2500

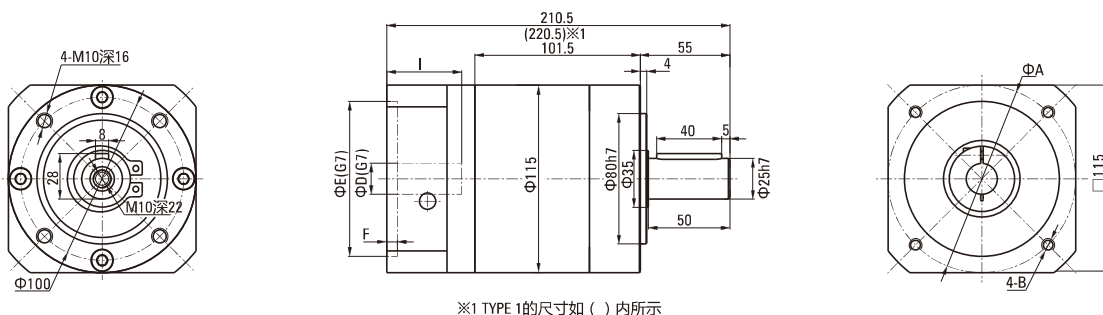

● 法兰部位详细尺寸表 Detailed Flange Dimensions Table (单位Unit:mm)

马达种类 Motor Type	A	B	C	D	E	F	I
T1	115	M8深(depth)20	100	19	95	5	55
T2	115	M6深(depth)15	100	24	95	5	45
T3	-	-	-	-	-	-	-

• T1~3的详细情况请参照P.156

• For details of T1~3, see 156 page

# ZDE/ZDF 2500W 尺寸图与性能表

## ZDE/ZDF 2500W DIMENSIONAL DRAWING & PERFORMANCE TABLE

### ZDE尺寸图 Dimensional Drawing

● 160ZDE10-2500

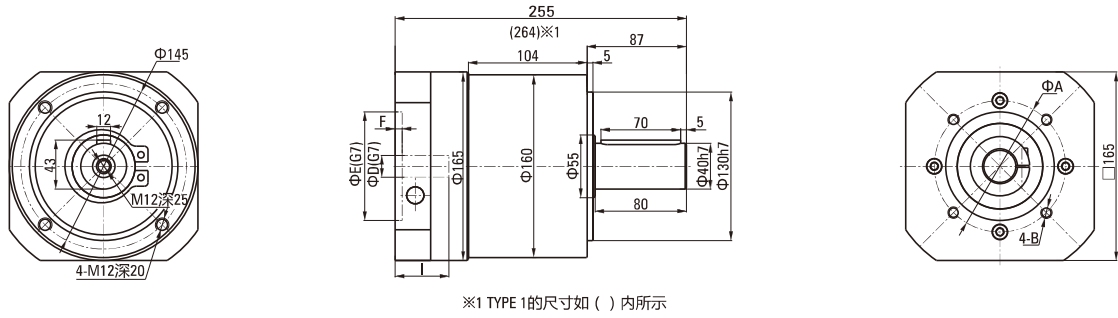

※1 TYPE 1的尺寸如 ( ) 内所示

● 160ZDE25-32-40-2500

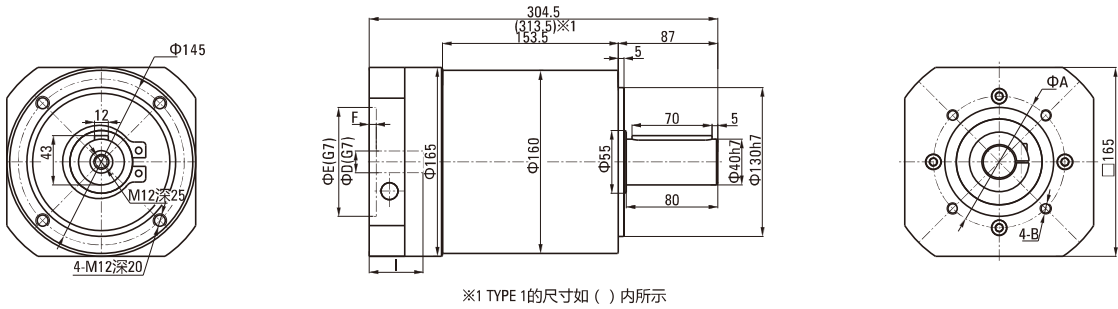

※1 TYPE 1的尺寸如 ( ) 内所示

### ● 法兰部位详细尺寸表 Detailed Flange Dimensions Table (单位Unit:mm)

马达种类 Motor Type	A	B	C	D	E	F	I
T1	115	M8深(depth)20	100	15	95	5	55
T2	46	M6深(depth)15	100	24	95	5	45
T3	-	-	-	-	-	-	-

• T1~3的详细情况请参照P.156  
 • For details of T1~3, see 156 page

# ZDE/ZDF 2500W 尺寸图与性能表

## ZDE/ZDF 2500W DIMENSIONAL DRAWING & PERFORMANCE TABLE

### ZDF尺寸图 Dimensional Drawing

● 80ZDF3-4-2500

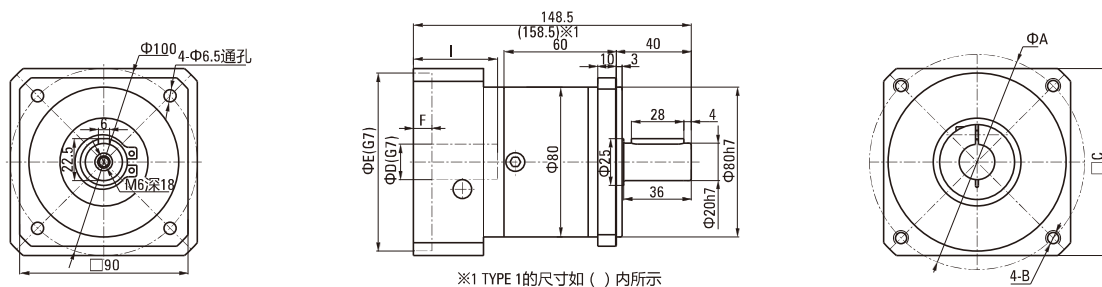

● 80ZDF9-2500

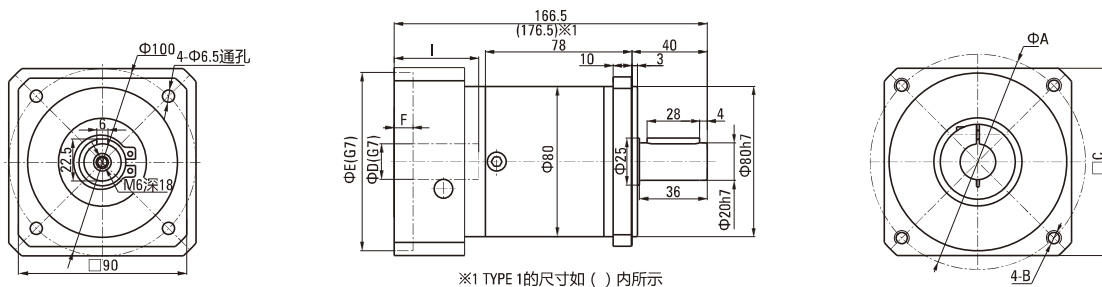

● 120ZDF5-8-2500

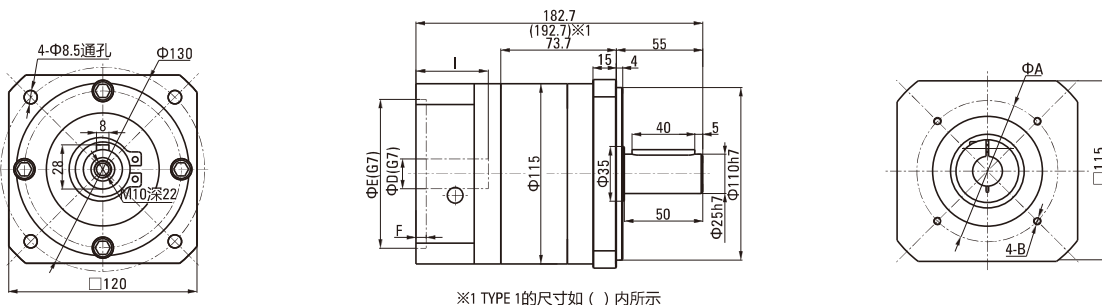

● 法兰部位详细尺寸表 Detailed Flange Dimensions Table

(单位Unit:mm)

马达种类 Motor Type	A	B	C	D	E	F	I
T1	115	M8深(depth)20	100	19	95	5	55
T2	115	M6深(depth)15	100	24	95	5	45
T3	-	-	-	-	-	-	-

• T1~3的详细情况请参照P156

• For details of T1~3, see 156 page

# ZDE/ZDF 2500W 尺寸图与性能表

## ZDE/ZDF 2500W DIMENSIONAL DRAWING & PERFORMANCE TABLE

### ZDF 尺寸图 Dimensional Drawing

● 120ZDF12-15-16-20-2500

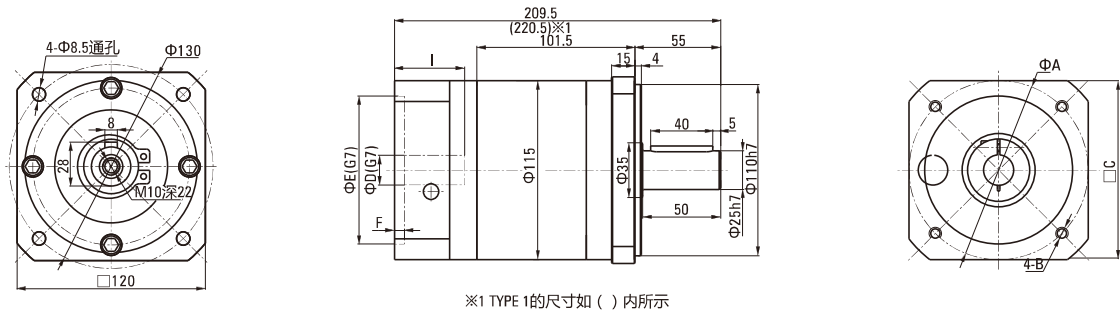

● 1600ZDF10-2500

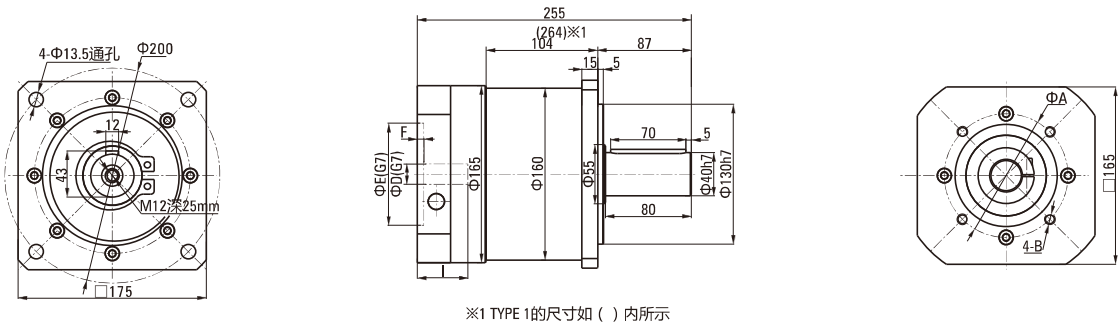

● 160ZDF25-32-40-2500

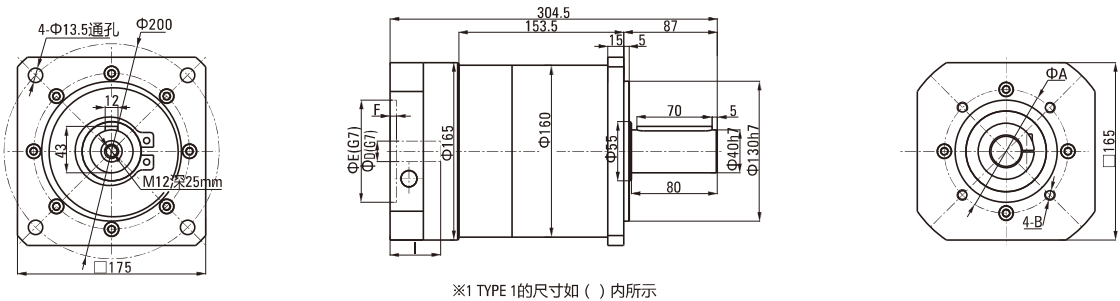

● 法兰部位详细尺寸表 Detailed Flange Dimensions Table

(单位Unit:mm)

马达种类 Motor Type	A	B	C	D	E	F	I
T1	115	M8深(depth)20	100	19	95	5	55
T2	115	M6深(depth)15	100	24	95	5	45
T3	-	-	-	-	-	-	-

• T1~3的详细情况请参照P.156  
• For details of T1~3, see 156 page