

直流电动机 DC MOTORS

■ 250W □ 90mm



电机性能参数 Motor Performance Parameters

| 型号 Model | 电压 Voltage V | 功率 Power W | 空载参数No-load Parameters | | 负载参数Load Parameters | | | 电刷寿命 Brush Life H | 电机重量 Motor Weight kg |
|---------------|--------------------|------------------|------------------------|----------------|---------------------|------------------|----------------|-------------------------|----------------------------|
| | | | 转速Speed r/min | 电流Current A | 转速Speed r/min | 力矩Torque mN.m | 电流Current A | | |
| Z55D250-24 □ | 24 | 250 | 3400 | 3.0 Max. | 3000 | 796 | 16.0 | 2000 | 3.2 |
| Z55D250-90 □ | 90 | 250 | 3300 | 1.2 Max. | 3000 | 796 | 4.2 | 2000 | 3.2 |
| Z55D250-220 □ | 220 | 250 | 3300 | 0.9 Max. | 3000 | 796 | 2.2 | 2000 | 3.2 |

● 电机电压、功率及转速可在配件尺寸等条件允许下根据客户要求定制。
Motor voltage, power and speed will be customized according to his requestment under the allowed circumstance of adoptable dimension.

种类 Type

● 电动机 Motor

| 机型 Type | 型号Model | | |
|-----------------------------|----------------------|--------------------|--------------------|
| | 齿轮轴型 Pinion Shaft | 圆轴型 Round Shaft | 圆轴型 Round Shaft |
| 导线型 Lead Wire Type | Z55D250-24GN | Z55D250-24A | Z55D250-24A1 |
| | Z55D250-90GN | Z55D250-90A | Z55D250-90A1 |
| | Z55D250-220GN | Z55D250-220A | Z55D250-220A1 |

● 平行轴减速器 (另售) Parallel Shaft Gearhead (Sold Separately)

| 减速器种类 Gearhead Type | 减速器型号 Gearhead Model | 减速比 Gear Ratio |
|-------------------------------------|-------------------------|---|
| 长寿命●低噪音 Long Life ● Low Noise | 5GU□KB | 3、3.6、5、6、7.5、9、 12.5、15、18、25、30、 36、50、60、75、90、 100、120、150、180、200 |
| | | 5GU10XX (中间减速器 Decimal Gearhead) |

● 减速器型号的□中为减速比的数值
Enter the gear ratio in the box (□) within the model name

● 电机特性曲线 Characteristic Curve Of Motor

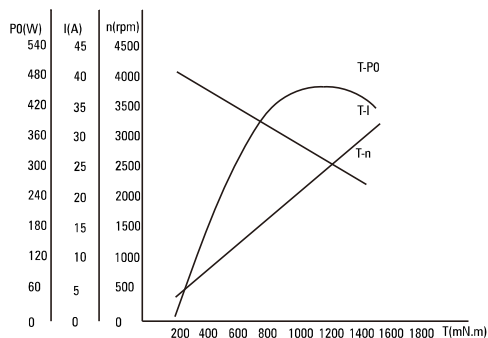

● 电机接线图 Wiring Diagram Of Motor

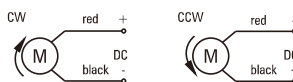

● 标准引出线长度:300mm±10,型号:UL1015规格:AWG14;电机引出线长度、型号在配件尺寸等条件允许的情况下可根据客户要求定制。
Standard length of lead wire:300mm±10, model: UL1015 type: AWG14; lead wire length, model will be customised by client requestment under allowed circumstance of adoptable dimension.

■ 装有减速器时的容许转矩 Gear Motor-Torque Table

- 减速器另售·中间减速器另售。
Gearheads are sold separately. Decimal gearheads are not available.
- 减速品型号的□中为减速比的数值。
Enter the gear ratio in the box (□) within the model name.
- □色表示与电动机同一方向运转，其他则为相反方向。
The colored background □ indicates the same rotating direction of the motor while the rotating direction of others are opposite.
- 转速是以电动机的额定转速为基准除以减速比而算出来的数值。实际转速将随负载大小变化而比所示数值减少2%~20%左右。
The speed is calculated by dividing the motor's synchronous speed by the gear ratio. The actual speed is 2%~20% less than the displayed value, depending on the size of the load.
- 希望以大于下表的减速比进行进一步减速时，可在电动机与减速机之间安装减速比为10的中间减速机。
这时的容许转矩为20N·m。
To reduce the speed beyond the gear ratio in the table, attach a decimal gearhead(gear ratio:10)between the gearhead and motor. In that case, the permissible torque is 20N·m.

■ 容许力矩单位 Allowance Torque Unit : 上段 Upside (N.m) /下段 Belowside (kgf.cm)

| 型号 Type | 减速比 Gear Ratio | 3 | 3.6 | 5 | 6 | 7.5 | 9 | 10 | 12.5 | 15 | 18 | 20 | 25 | 30 | 36 | 40 | 50 | 60 | 75 | 90 | 100 | 120 | 150 | 180 | 200 |
|--------------|----------------|------|------|------|------|------|------|------|------|------|------|------|------|------|------|------|------|------|------|------|------|------|------|------|------|
| Z55D250-24GU | 转速 Speed r/min | 1000 | 833 | 600 | 500 | 400 | 333 | 300 | 240 | 200 | 167 | 150 | 120 | 100 | 83 | 75 | 60 | 50 | 40 | 33 | 30 | 25 | 20 | 17 | 15 |
| | 5GU□KB | 1.93 | 2.32 | 3.22 | 3.87 | 4.83 | 5.80 | 5.80 | 7.25 | 8.70 | 10.4 | 10.4 | 13.1 | 15.7 | 18.8 | 20.0 | 20.0 | 20.0 | 20.0 | 20.0 | 20.0 | 20.0 | 20.0 | 20.0 | 20.0 |
| | | 19.0 | 22.7 | 31.6 | 37.9 | 47.4 | 56.9 | 56.9 | 71.1 | 85.3 | 102 | 102 | 128 | 154 | 184 | 200 | 200 | 200 | 200 | 200 | 200 | 200 | 200 | 200 | 200 |

■ 容许悬挂负载·容许轴向负载 To Allow The Hoisting Of The Load Allow Axial Load

电动机(圆轴型)→272页 Motor(Round Shaft)→P272
减速机→272页 Gearhead→P272

■ 减速机的容许负载惯性惯量 J Permissible Load Inertia J For Gearhead

→272页→P272

● 圆轴型的转轴部分 Shaft Section Of Round Shaft Type

除重量及轴部外电动机外形与齿轮轴型相同。
Excluding weight and the shaft section motor shape are the same as those of the pinion shaft type.

■ 外形图(单位 mm) Dimensions(Unit mm)

减速器附有安装用螺丝Mounting screws are included with gearhead.

● 导线型 Lead Wiring Type

重量 Weight : 电动机 Motor : 3.2kg 减速器 Gearhead : 1.5kg

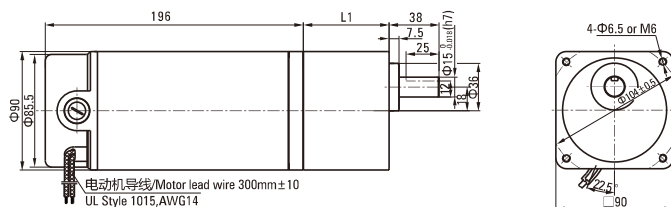

| 电动机型号 Motor Model | 减速器型号 Gearhead Model | 减速比 Gear Ratio | L1 |
|---|----------------------|----------------|------|
| Z55D250-24GU Z55D250-90GU Z55D250-220GU | 5GU□KB | 3~200 | 65.5 |

● 减速器型号的□中为减速比的数值 Enter the gear ratio in the box (□) within the model name

● 凸缘安装型减速器 Flange Mounting Reducer

可安装在GU齿轮轴型上 Can be mounted on GU type gear shaft 5GU□K
重量 Weight: 1.5kg

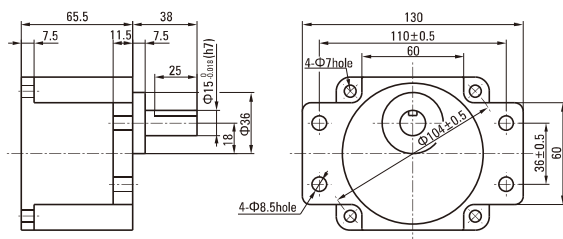

● 键·键槽(减速器附件)

Key·Keyway (The Key Is Included With The Gearhead)

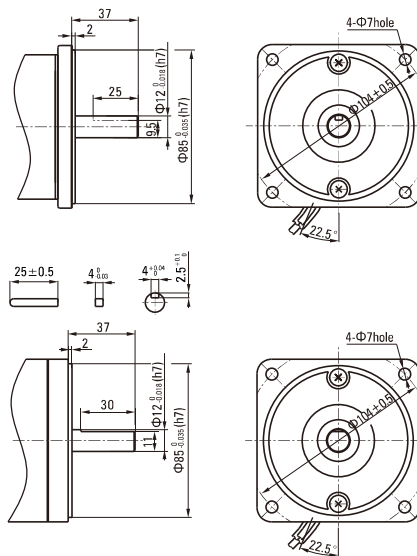
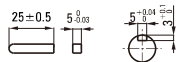

● 中间减速器 Decimal Gearhead

可安装在GU齿轮轴型上 Can be connected to GU pinion shaft type
电动机外形与齿轮轴型相同
5GU10X
重量 Weight : 0.651kg

