

直流电动机

DC MOTORS

■ 90W □ 90mm



电机性能参数 Motor Performance Parameters

型号 Model	电压 Voltage	功率 Power	空载参数No-load Parameters		负载参数Load Parameters			电刷寿命 Brush Life	电机重量 Motor Weight
			转速Speed	电流Current	转速Speed	力矩Torque	电流Current		
	V	W	r/min	A	r/min	mN.m	A	H	kg
Z5D90-12□	12	90	3100	2.0 Max.	2600	330	12.0	2000	2.2
Z5D90-24□	24	90	3300	1.0 Max.	2800	307	5.0	2000	2.2
Z5D90-90□	90	90	3000	0.3 Max.	2900	307	1.4	2000	2.2

● 电机电压、功率及转速可在配件尺寸等条件允许下根据客户要求定制。

Motor voltage, power and speed will be customized according to his requestment under the allowed circumstance of adoptable dimension.

种类 Type

● 电动机 Motor

机型 Type	型号Model		
	齿轮轴型 Pinion Shaft	圆轴型 Round Shaft	圆轴型 Round Shaft
导线型 Lead Wire Type	Z5D90-12GN	Z5D90-12A	Z5D90-12A1
	Z5D90-24GN	Z5D90-24A	Z5D90-24A1
	Z5D90-90GN	Z5D90-90A	Z5D90-90A1

● 平行轴减速器 (另售) Parallel Shaft Gearhead (Sold Separately)

减速器种类 Gearhead Type	减速器型号 Gearhead Model	减速比 Gear Ratio
长寿命●低噪音 Long Life ● Low Noise	5GU□KB	3、3.6、5、6、7.5、9、 12.5、15、18、25、30、 36、50、60、75、90、 100、120、150、180、200
	5GU10XK (中间减速器 Decimal Gearhead)	

● 减速器型号的□中为减速比的数值

Enter the gear ratio in the box (□) within the model name

● 电机特性曲线 Characteristic Curve Of Motor

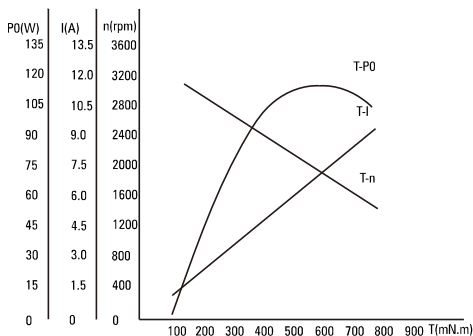

● 电机接线图 Wiring Diagram Of Motor

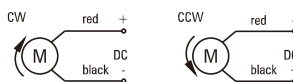

● 标准引出线长度:300mm±10,型号:UL1015规格:AWG16;电机引出线长度、型号在配件尺寸等条件允许的情况下可根据客户要求定制。

Standard length of lead wire:300mm±10, model: U1015 type: AWG16; lead wire length, model will be customised by dient requestmant under allowed circumstance of adoptable dimension.

■ 装有减速器时的容许转矩 Gear Motor-Torque Table

- 减速器另售·中间减速器另售。
Gearheads are sold separately. Decimal gearheads are not available.
- 减速品型号的□中为减速比的数值。
Enter the gear ratio in the box (□) within the model name.
- □色表示与电动机同一方向运转，其他则为相反方向。
The colored background □ indicates the same rotating direction of the motor while the rotating direction of others are opposite.
- 转速是以电动机的额定转速为基准除以减速比而算出来的数值。实际转速将随负载大小变化而比所示数值减少2%~20%左右。
The speed is calculated by dividing the motor's synchronous speed by the gear ratio. The actual speed is 2%~20% less than the displayed value, depending on the size of the load.
- 希望以大于下表的减速比进行进一步减速时，可在电动机与减速机之间安装减速比为10的中间减速机。
这时的容许转矩为20N·m。
To reduce the speed beyond the gear ratio in the table, attach a decimal gearhead(gear ratio:10)between the gearhead and motor. In that case, the permissible torque is 20N·m.

■ 容许力矩单位 Allowance Torque Unit : 上段 Upside (N.m) /下段 Belowside (kgf.cm)

型号 Type	减速比 Gear Ratio	3	3.6	5	6	7.5	9	10	12.5	15	18	20	25	30	36	40	50	60	75	90	100	120	150	180	200
Z5D90-24GU	转速 Speed r/min	933	778	560	467	373	311	280	224	187	156	140	112	93	78	70	56	47	37	31	28	23	19	16	14
	5GU□KB	0.75	0.90	1.24	1.49	1.86	2.24	2.24	2.80	3.36	4.03	4.03	5.03	6.04	7.25	8.06	10.1	12.4	15.1	16.3	18.1	20.0	20.0	20.0	20.0
		7.31	8.77	12.2	14.6	18.3	21.9	21.9	27.4	32.9	39.5	39.5	49.3	59.2	71.1	78.9	98.7	118	148	160	178	200	200	200	200

■ 容许悬挂负载·容许轴向负载 To Allow The Hoisting Of The Load Allow Axial Load

电动机(圆轴型) → P272页 Motor(Round Shaft) → P272
减速机 → P272页 Gearhead → P272

■ 减速机的容许负载惯性惯量 J Permissible Load Inertia J For Gearhead

→ P272页 → P272

● 圆轴型的转轴部分 Shaft Section Of Round Shaft Type

除重量及轴部外电动机外形与齿轮轴型相同。
Excluding weight and the shaft section motor shape are the same as those of the pinion shaft type.

■ 外形图(单位 mm) Dimensions(Unit mm)

减速器附有安装用螺丝 Mounting screws are included with gearhead.

● 导线型 Lead Wiring Type

重量 Weight : 电动机 Motor : 2.2kg 减速机 Gearhead : 1.5kg

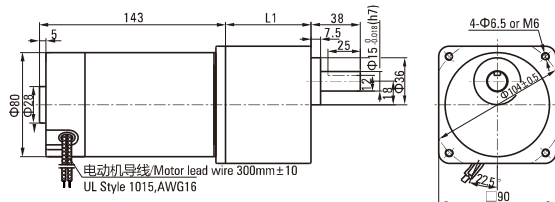

电动机型号 Motor Model	减速器型号 Gearhead Model	减速比 Gear Ratio	L1
Z5D90-12GU Z5D90-24GU Z5D90-90GU	5GU□KB	3~200	65.5

● 减速器型号的□中为减速比的数值 Enter the gear ratio in the box (□) within the model name

● 凸缘安装型减速机 Flange Mounting Reducer

可安装在GU齿轮轴型上 Can be mounted on GU type gear shaft 5GU□K
重量 Weight: 1.5kg

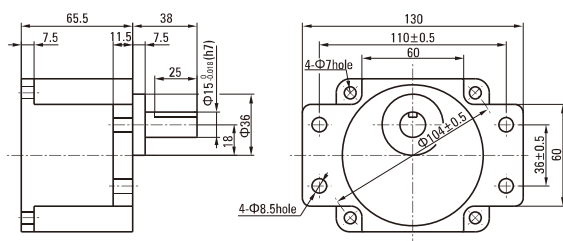

● 键·键槽(减速机附件) Key·Keyway (The Key Is Included With The Gearhead)

Key·Keyway (The Key Is Included With The Gearhead)

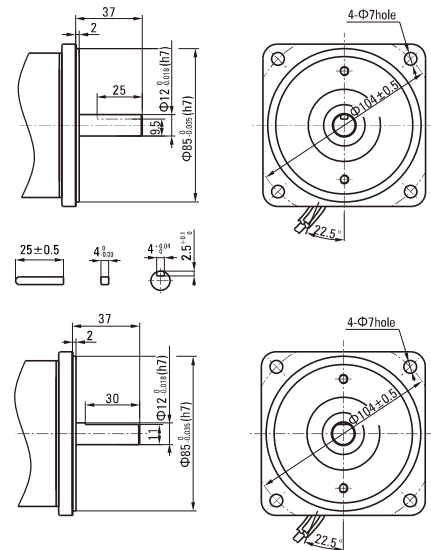

● 中间减速器 Decimal Gearhead

可安装在GU齿轮轴型上 Can be connected to GU pinion shaft type
电动机外形与齿轮轴型相同

5GU10X

重量 Weight : 0.651kg

