

直流电动机

DC MOTORS

■ 25W □ 70mm

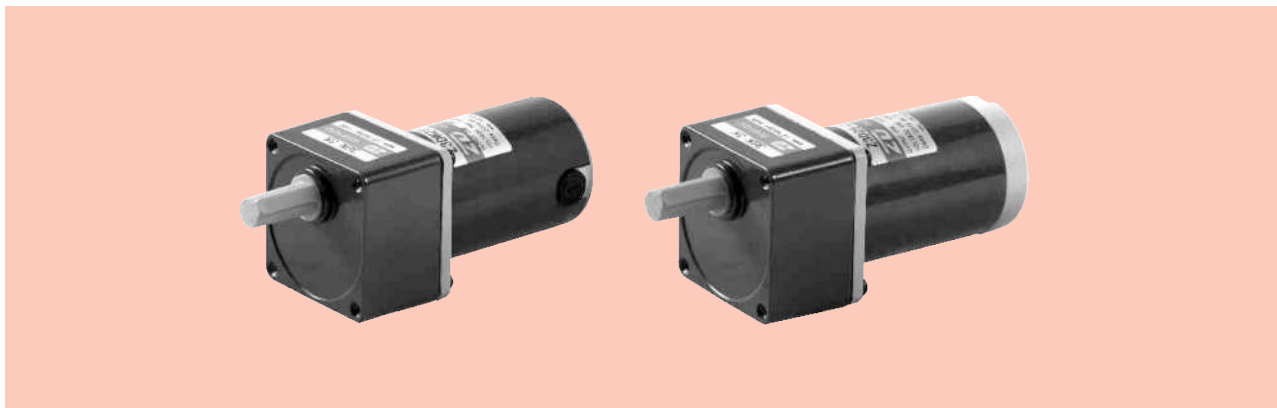

电机性能参数 Motor Performance Parameters

型号 Model	电压 Voltage V	功率 Power W	空载参数No-load Parameters		负载参数Load Parameters			电刷寿命 Brush Life H	电机重量 Motor Weight kg
			转速Speed r/min	电流Current A	转速Speed r/min	力矩Torque mN.m	电流Current A		
Z3D25-12 □	12	25	3300	1.0 Max.	3000	80	3.5	2000	1.0
Z3DW25-12□	12	25	3300	1.0 Max.	3000	80	3.5	2000	1.0
Z3D25-24 □	24	25	3200	0.5 Max.	2800	85	1.6	2000	1.0
Z3DW25-24□	24	25	3200	0.5 Max.	2800	85	1.6	2000	1.0
Z3D25-90 □	90	25	3100	0.3 Max.	2700	88	0.6	2000	1.0
Z3DW25-90□	90	25	3100	0.3 Max.	2700	88	0.6	2000	1.0

●电机电压、功率及转速可在配件尺寸等条件下根据客户要求定制。

Motor voltage, power and speed will be customized according to his requestment under the allowed circumstance of adoptable dimension.

●D后如加W即Z2DW06-12GN表示外置电刷齿轴电机，如无W则为标准内置电刷齿轴电机：外置电刷电机，用户可自行在外部更换电刷；内置电刷电机更换电刷时需将电机拆装后方可更换。

We use W after D in the model to express the external brush motor, such as Z2DW06-12GN. If no W, it means the standard internal brush motor. For external brush motor, you can replace the brush directly. For internal ones, we need to disassembly the motor first.

种类 Type

● 电动机 Motor

机型 Type	型号Model	
	齿轮轴型 Pinion Shaft	圆轴型 Round Shaft
导线型 Lead Wire Type	Z3D25-12GN	Z3D25-12A
	Z3DW25-12GN	Z3DW25-12A
	Z3D25-24GN	Z3D25-24A
	Z3DW25-24GN	Z3D25-24A
	Z3D25-90GN	Z3D25-90A
	Z3DW25-90GN	Z3DW25-90A

● 电机特性曲线 Characteristic Curve Of Motor

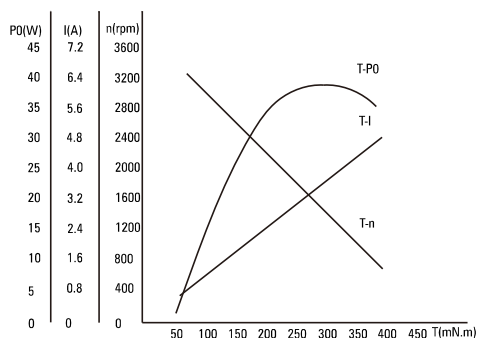

● 平行轴减速器 (另售) Parallel Shaft Gearhead (Sold Separately)

减速器种类 Gearhead Type	减速器型号 Gearhead Model	减速比 Gear Ratio
长寿命●低噪音 Long Life ● Low Noise	3GN□K	3、3.6、5、6、7.5、9、 12.5、15、18、25、30、 36、50、60、75、90、 100、120、150、180、200
		3GN10XK (中间减速器 Decimal Gearhead)

●减速器型号的□中为减速比的数值

Enter the gear ratio in the box (□) within the model name

● 电机接线图 Wiring Diagram Of Motor

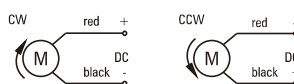

●标准引出线长度:300mm±10,型号:UL1015规格:AWG20;电机引出线长度、型号在配件尺寸等条件下可根据客户要求定制。

Standard length of lead wire:300mm±10, model: UL1015 type: AWG20; lead wire length, model will be customised by client requestment under allowed circumstance of adoptable dimension.

■ 装有减速器时的容许转矩 Gear Motor-Torque Table

- 减速器另售·中间减速器另售。
Gearheads are sold separately. Decimal gearheads are not available.
- 减速品型号的□中为减速比的数值。
Enter the gear ratio in the box (□) within the model name.
- □色表示与电动机同一方向运转，其他则为相反方向。
The colored background □ indicates the same rotating direction of the motor while the rotating direction of others are opposite.
- 转速是以电动机的额定转速为基准除以减速比而算出来的数值。实际转速将随负载大小变化而比所示数值减少2%~20%左右。
The speed is calculated by dividing the motor's synchronous speed by the gear ratio. The actual speed is 2%~20% less than the displayed value, depending on the size of the load.
- 希望以大于下表的减速比进行进一步减速时，可在电动机与减速机之间安装减速比为10的中间减速机。
这时的容许转矩为5N·m。
To reduce the speed beyond the gear ratio in the table, attach a decimal gearhead(gear ratio:10)between the gearhead and motor. In that case, the permissible torque is 5N·m.

■ 容许力矩单位 Allowance Torque Unit : 上段 Upside (N.m) /下段 Belowside (kgf.cm)

型号 Type	减速比 Gear Ratio	3	3.6	5	6	7.5	9	10	12.5	15	18	20	25	30	36	40	50	60	75	90	100	120	150	180	200
Z3D25-24GN	转速 Speed r/min	933	778	560	467	373	311	280	224	187	156	140	112	93	78	70	56	47	37	31	28	23	19	16	14
	3GN□K	0.21	0.25	0.35	0.41	0.52	0.62	0.69	0.86	1.04	1.24	1.24	1.55	1.86	2.24	2.49	3.11	3.73	4.66	5.00	5.00	5.00	5.00	5.00	5.00
		2.03	2.44	3.38	4.06	5.08	6.09	6.77	8.46	10.2	12.2	12.2	15.2	18.3	21.9	24.4	30.5	36.6	45.7	50.0	50.0	50.0	50.0	50.0	50.0

■ 容许悬挂负载·容许轴向负载 To Allow The Hoisting Of The Load Allow Axial Load

电动机 (圆轴型) → 272页

Motor(Round Shaft) → P272

减速机 → 272页

Gearhead → P272

■ 减速机的容许负载惯性惯量 J Permissible Load Inertia J For Gearhead

→ 272页 → P272

● 键·键槽 (减速机附件)

Key●Keyway (The Key Is Included With The Gearhead)

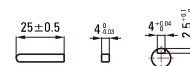

■ 外形图 (单位 mm) Dimensions(Unit mm)

减速机附有安装用螺丝 Mounting screws are included with gearhead.

● 导线型 Lead Wiring Type

重量 Weight : 电动机 Motor : 1.0kg

减速机 Gearhead : 0.55kg

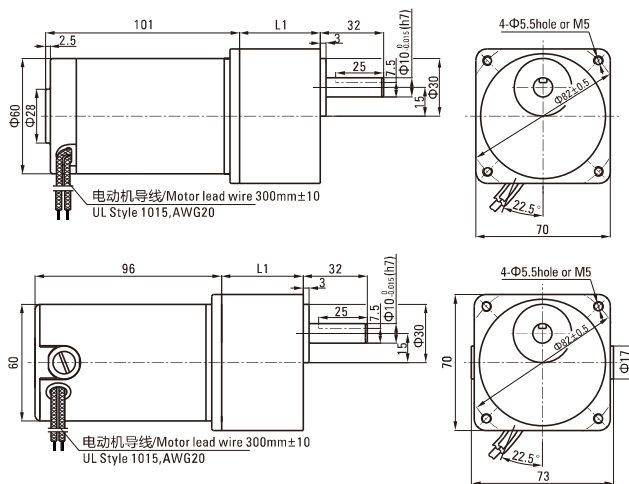

● 圆轴型的转轴部分 Shaft Section Of Round Shaft Type

除重量及轴部外电动机外形与齿轮轴型相同。

Excluding weight and the shaft section motor shape are the same as those of the pinion shaft type.

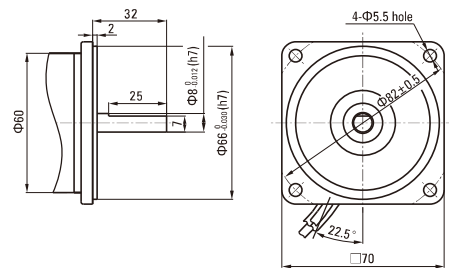

● 中间减速机 Decimal Gearhead

可安装在GN齿轮轴型上 Can be connected to GN pinion shaft type

电动机外形与齿轮轴型相同

3GN10X

重量 Weight : 0.31kg

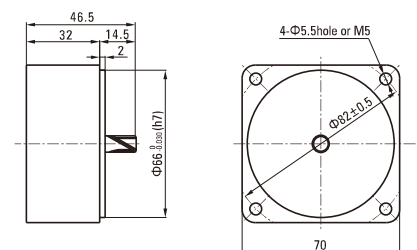

电动机型号 Motor Model	减速器型号 Gearhead Model	减速比 Gear Ratio	L1
Z3D25-12GN Z3DW25-12GN Z3D25-24GN Z3DW25-24GN Z3D25-90GN Z3DW25-90GN	3GN□K	3~18	32
		25~200	42

● 减速器型号的□中为减速比的数值 Enter the gear ratio in the box (□) within the model name