

直流电动机 DC MOTORS

■ 15W □ 60mm

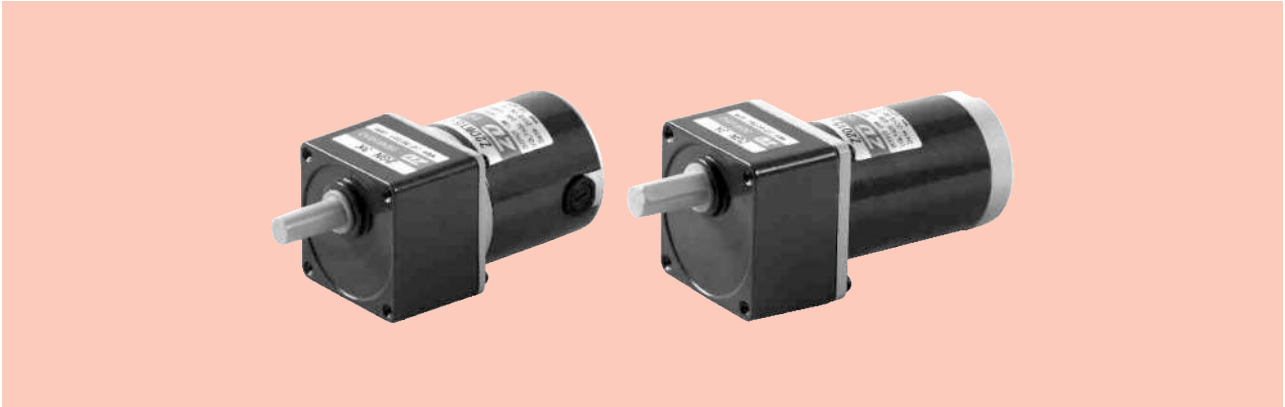

电机性能参数 Motor Performance Parameters

型号 Model	电压 Voltage V	功率 Power W	空载参数No-load Parameters		负载参数Load Parameters			电刷寿命 Brush Life H	电机重量 Motor Weight kg
			转速Speed r/min	电流Current A	转速Speed r/min	力矩Torque mN.m	电流Current A		
Z2D15-12 □	12	15	3200	0.8 Max.	2950	48	2.0	2000	0.9
Z2DW15-12□	12	15	3200	0.8 Max.	2950	48	2.0	2000	0.9
Z2D15-24 □	24	15	3300	0.4 Max.	3000	48	1.0	2000	0.9
Z2DW15-24□	24	15	3300	0.4 Max.	3000	48	1.0	2000	0.9
Z2D15-90 □	90	15	3200	0.2 Max.	3000	48	0.4	2000	0.9
Z2DW15-90□	90	15	3200	0.2 Max.	3000	48	0.4	2000	0.9

●电机电压、功率及转速可在配件尺寸等条件下根据客户要求定制。

Motor voltage, power and speed will be customized according to his requestment under the allowed circumstance of adoptable dimension.

●D后如加W即Z2DW06-12GN表示外置电刷齿轴电机，如无W则为标准内置电刷齿轴电机：外置电刷电机，用户可自行在外部更换电刷；内置电刷电机更换电刷时需将电机拆装后方可更换。

We use W after D in the model to express the external brush motor, such as Z2DW06-12GN. If no W, it means the standard internal brush motor. For external brush motor, you can replace the brush directly. For internal ones, we need to disassembly the motor first.

种类 Type

● 电动机 Motor

机型 Type	型号Model	
	齿轮轴型 Pinion Shaft	圆轴型 Round Shaft
导线型 Lead Wire Type	Z2D15-12GN	Z2D15-12A
	Z2DW15-12GN	Z2DW15-12A
	Z2D15-24GN	Z2D15-24A
	Z2DW15-24GN	Z2D15-24A
	Z2D15-90GN	Z2D15-90A
	Z2DW15-90GN	Z2DW15-90A

● 电机特性曲线 Characteristic Curve Of Motor

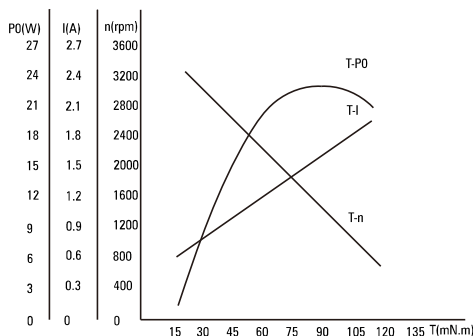

● 平行轴减速器（另售） Parallel Shaft Gearhead (Sold Separately)

减速器种类 Gearhead Type	减速器型号 Gearhead Model	减速比 Gear Ratio
长寿命●低噪音 Long Life ● Low Noise	2GN□K	3、3.6、5、6、7.5、9、 12.5、15、18、25、30、 36、50、60、75、90、 100、120、150、180、200
		2GN10XK (中间减速器 Decimal Gearhead)

●减速器型号的□中为减速比的数值

Enter the gear ratio in the box (□) within the model name

● 电机接线图 Wiring Diagram Of Motor

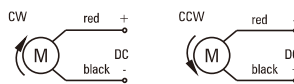

●标准引出线长度:300mm±10;型号:UL1015规格:AWG20;电机引出线长度、型号在配件尺寸等条件下可根据客户要求定制。

Standard length of lead wire:300mm±10, model: UL1015 type: AWG20; lead wire length, model will be customised by client requestment under allowed circumstance of adoptable dimension.

■ 装有减速器时的容许转矩 Gear Motor-Torque Table

- 减速器另售·中间减速器另售。
Gearheads are sold separately. Decimal gearheads are not available.
- 减速品型号的□中为减速比的数值。
Enter the gear ratio in the box (□) within the model name.
- □色表示与电动机同一方向运转，其他则为相反方向。
The colored background □ indicates the same rotating direction of the motor while the rotating direction of others are opposite.
- 转速是以电动机的额定转速为基准除以减速比而算出来的数值。实际转速将随负载大小变化而比所示数值减少2%~20%左右。
The speed is calculated by dividing the motor's synchronous speed by the gear ratio. The actual speed is 2%~20% less than the displayed value, depending on the size of the load.
- 希望以大于下表的减速比进行进一步减速时，可在电动机与减速机之间安装减速比为10的中间减速机。
这时的容许转矩为3N·m。
To reduce the speed beyond the gear ratio in the table, attach a decimal gearhead(gear ratio:10)between the gearhead and motor. In that case, the permissible torque is 3N·m.

■ 容许力矩单位 Allowance Torque Unit : 上段 Upside (N.m) /下段 Belowside (kgf.cm)

型号 Type	减速比 Gear Ratio	3	3.6	5	6	7.5	9	10	12.5	15	18	20	25	30	36	40	50	60	75	90	100	120	150	180	200
Z2D15-24GN	转速 Speed r/min	1000	833	600	500	400	333	300	240	200	167	150	120	100	83	75	60	50	40	33	30	25	20	17	15
	2GN□K	0.12	0.14	0.19	0.23	0.29	0.35	0.39	0.48	0.58	0.70	0.70	0.87	1.04	1.25	1.39	1.74	1.88	2.35	2.82	3.00	3.00	3.00	3.00	3.00
		1.14	1.36	1.90	2.27	2.84	3.41	3.79	4.74	5.69	6.82	6.82	8.53	10.23	12.28	13.65	17.1	18.4	23.0	27.6	30.0	30.0	30.0	30.0	30.0

■ 容许悬挂负载·容许轴向负载 To Allow The Hoisting Of The Load Allow Axial Load

电动机(圆轴型)→P272页

Motor(Round Shaft)→P272

减速机→P272页

Gearhead→P272

■ 减速机的容许负载惯性惯量 J Permissible Load Inertia J For Gearhead

→P272页→P272

■ 外形图(单位 mm) Dimensions(Unit mm)

减速器附有安装用螺丝 Mounting screws are included with gearhead.

● 导线型 Lead Wiring Type

重量 Weight : 电动机 Motor : 0.9kg

减速器 Gearhead : 0.4kg

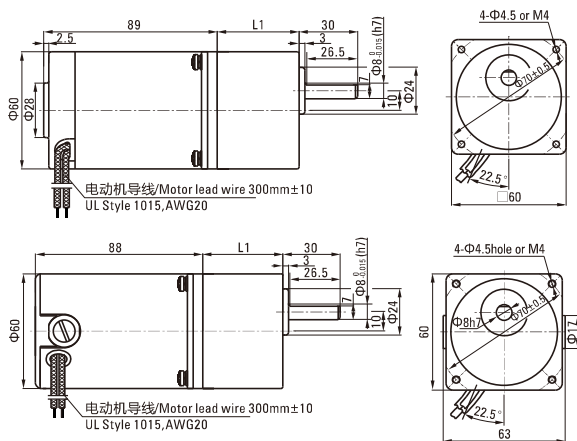

● 圆轴型的转轴部分 Shaft Section Of Round Shaft Type

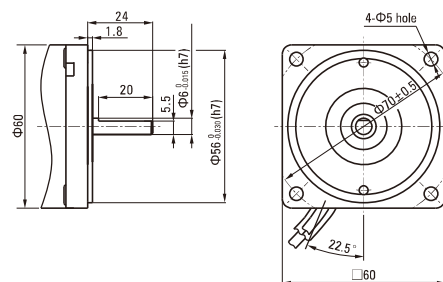
除重量及轴部外电动机外形与齿轮轴型相同。
Excluding weight and the shaft section motor shape are the same as those of the pinion shaft type.

● 中间减速器 Decimal Gearhead

可安装在GN齿轮轴型上 Can be connected to GN pinion shaft type
电动机外形与齿轮轴型相同

2GN10X

重量 Weight : 0.24kg

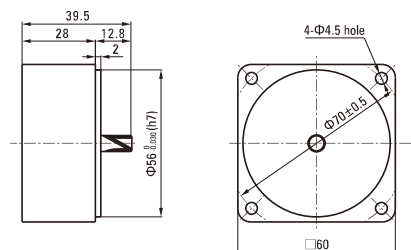

电动机型号 Motor Model	减速器型号 Gearhead Model	减速比 Gear Ratio	L1
Z2D15-12GN Z2DW15-12GN Z2D15-24GN Z2DW15-24GN	2GN□K	3~18	32
Z2D15-90GN Z2DW15-90GN		25~200	41

● 减速器型号的□中为减速比的数值 Enter the gear ratio in the box (□) within the model name