

ZDF2尺寸图

ZDF2 SIZE CHART

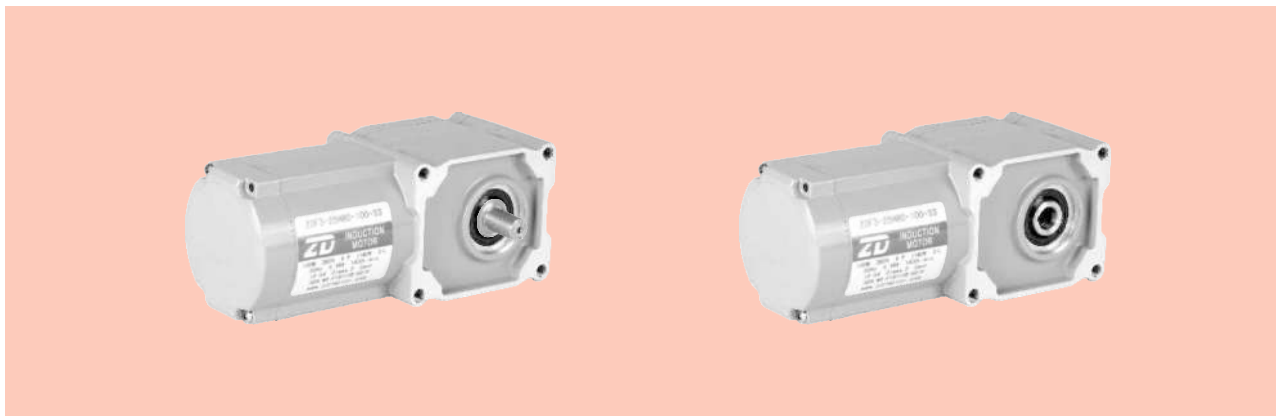

规格 · 连续额定 Specification And Continuous Rating

型号 Model	输出功率 Output Power	电压 Voltage	频率 Frequency	额定电流 Rated Current	额定转矩 Rated Torque	额定转速 Rated Speed	堵转转矩 Locked Rotor Torque	堵转电流 Locked Rotor Current	绝缘等级 Insulation Grade
	W	V	Hz	A	N.m	r/min	N.m	A	
ZDF2-15H□-60-S-F(TB)	60	200	60	0.40	0.36	1600	0.90	1.30	F
		220	50	0.50	0.44	1350	1.40	1.40	
ZDF2-15H□-60-S ₃ -F(TB)		380	50	0.28	0.44	1350	1.40	0.75	
		460	60	0.28	0.36	1600	1.50	0.85	

型号 Model	输出功率 Output Power	电压 Voltage	频率 Frequency	额定电流 Rated Current	额定转矩 Rated Torque	额定转速 Rated Speed	堵转转矩 Locked Rotor Torque	堵转电流 Locked Rotor Current	电容器 Capacitor	绝缘等级 Insulation Grade
	W	V	Hz	A	N.m	r/min	N.m	A	UF	
ZDF2-18A□-60-C-F(TB)	60	200	60	0.47	0.36	1600	0.23	0.95	3.00	F
		220	50	0.49	0.44	1300	0.23	1.10		
ZDF2-18A□-60-A-F(TB)		110	50	1.00	0.44	1300	0.23	2.10	12.0	
		110	60	0.90	0.36	1600	0.23	1.95		

功率 Power	孔径/轴径 Aperture/Axis Diameter	减速比 Reduction Ratio	输出轴转速 Output Shaft Speed		输出轴容许转矩 Output Shaft Torque		输出轴容许 Output Shaft Tolerance		输出轴容许 Output Shaft Tolerance	
			r/min	50Hz	N.m	kgf.m	N	kgf	N	kgf
60	15/18	i	50Hz	50Hz	50Hz	N	kgf	N	kgf	
		10	150	3.560	0.36	343	35	108	11	
		15	100	5.340	0.54	441	45	147	15	
		20	75.0	7.120	0.72	539	55	186	19	
		25	60.0	8.910	0.90	588	60	226	23	
		30	50.0	10.69	1.09	686	70	245	25	
		40	37.5	14.25	1.45	784	80	275	28	
		50	30.0	17.82	1.81	882	90	294	30	
		60	25.0	21.38	2.18	882	90	294	30	
		80	18.8	25.66	2.61	1270	130	324	33	
		100	15.0	32.07	3.27	1270	130	324	33	
		120	12.5	38.49	3.92	1370	140	343	35	
		160	9.40	51.32	5.23	1370	140	343	35	
		※200	7.50	53.90	5.50	1370	140	343	35	
※240	6.30	53.90	5.50	1370	140	343	35			

注：带※号的为转矩力限制机种，使用时请阅读本表。Note: The number for the torque limit model, please read this table.

ZDF2尺寸图

ZDF2 SIZE CHART

规格·连续额定 Specification And Continuous Rating

型号 Model	输出功率 Output Power	电压 Voltage	频率 Frequency	额定电流 Rated Current	额定转矩 Rated Torque	额定转速 Rated Speed	堵转转矩 Locked Rotor Torque	堵转电流 Locked Rotor Current	绝缘等级 Insulation Grade
	W	V	Hz	A	N.m	r/min	N.m	A	
ZDF2-15H□-90-S-F(TB)	90	200	60	0.55	0.57	1500	1.30	1.55	F
		220	50	0.68	0.66	1300	1.90	1.75	
ZDF2-15H□-90-S ₃ -F(TB)		380	50	0.38	0.66	1300	1.90	0.95	
		460	60	0.37	0.54	1600	2.00	1.05	

型号 Model	输出功率 Output Power	电压 Voltage	频率 Frequency	额定电流 Rated Current	额定转矩 Rated Torque	额定转速 Rated Speed	堵转转矩 Locked Rotor Torque	堵转电流 Locked Rotor Current	电容器 Capacitor	绝缘等级 Insulation Grade
	W	V	Hz	A	N.m	r/min	N.m	A	UF	
ZDF2-18A□-90-C-F(TB)	90	200	60	0.68	0.55	1550	0.40	1.30	4.50	F
		220	50	0.75	0.68	1250	0.40	1.40		
ZDF2-18A□-90-A-F(TB)		110	50	1.45	0.68	1250	0.40	2.80	20.0	
		110	60	1.45	0.55	1550	0.40	2.60		

功率 Power	孔径/轴径 Aperture/Axis Diameter	减速比 Reduction Ratio	输出轴转速 Output Shaft Speed		输出轴容许转矩 Output Shaft Torque		输出轴容许 Output Shaft Tolerance		输出轴容许 Output Shaft Tolerance	
			r/min	50Hz	N.m	kgf.m	N	kgf	轴向力负载 Axial Force Load	N
90	15/18	10	150	5.340	0.54	441	45	108	11	
		15	100	8.010	0.81	588	60	147	15	
		20	75.0	10.69	1.09	735	75	186	19	
		25	60.0	13.36	1.36	882	90	226	23	
		30	50.0	16.03	1.63	980	100	245	25	
		40	37.5	21.38	2.18	1080	110	275	28	
		50	30.0	26.73	1.70	1180	120	294	30	
		60	25.0	32.07	3.27	1180	120	294	30	
		80	18.8	38.49	3.92	1270	130	324	33	
		100	15.0	48.11	4.90	1270	130	324	33	
		※120	12.5	53.90	5.50	1370	140	343	35	
		※160	9.40	53.90	5.50	1370	140	343	35	
		※200	7.50	53.90	5.50	1370	140	343	35	
		※240	6.30	53.90	5.50	1370	140	343	35	

注：带※号的为转矩力限制机种，使用时请阅读本表。 Note: The number for the torque limit model, please read this table.

外形图 OUTLINE DRAWING

ZDF2-15H10~240-60~90-C-TF
ZDF2-15H10~240-60~90-S-TF
ZDF2-15H10~240-60~90-S-TBF

ZDF2-15H10~240-60~90-A-TF
ZDF2-15H10~240-60~90-S3-TF
ZDF2-15H10~240-60~90-S3-TBF

ZDF2-15H10~240-60~90-S3-TF
ZDF2-15H10~240-60~90-A-TBF

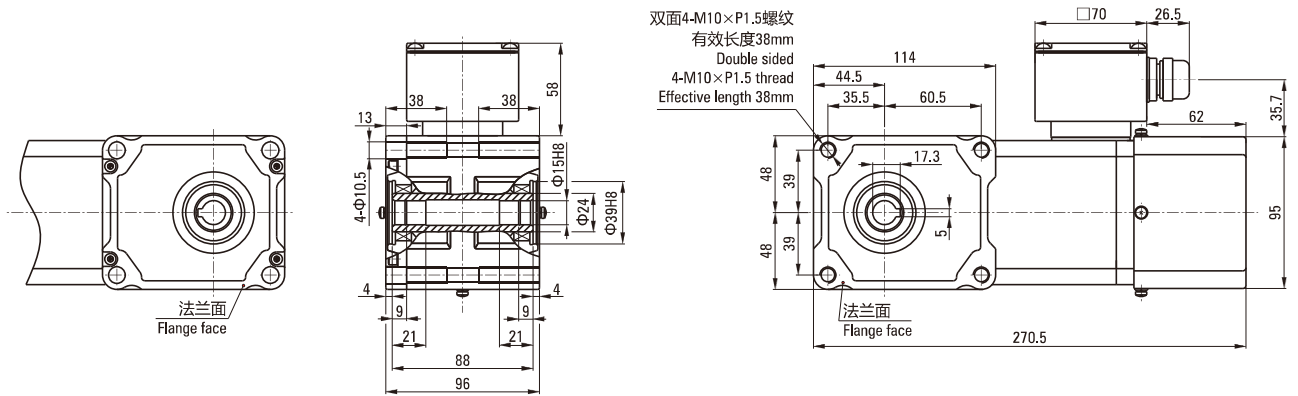

注：常规产品不带接线盒 Note: Conventional products without wiring box

ZDF2-18A10_R~240-60~90-C-TF
ZDF2-18A10_R~240-60~90-C-TBF
ZDF2-18A10_R~240-60~90-S-TBF

ZDF2-18A10_R~240-60~90-A-TF
ZDF2-18A10_R~240-60~90-A-TBF
ZDF2-18A10_R~240-60~90-S3-TBF

ZDF2-18A10_R~240-60~90-S-TF
ZDF2-18A10_R~240-60~90-S3-TF

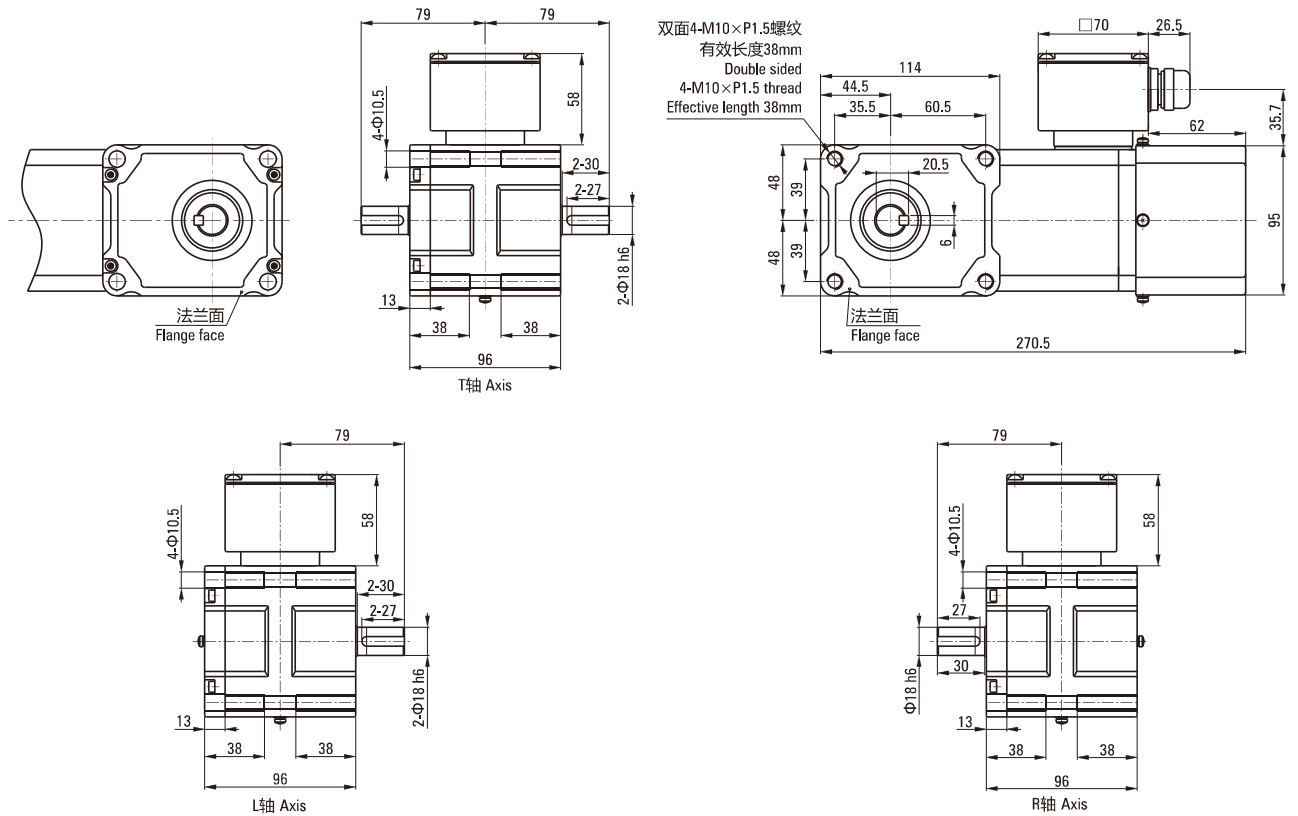

注：常规产品不带接线盒 Note: Conventional products without wiring box