

无励磁动作型电磁制动电动机 POWER OFF ACTIVATED TYPE ELECTROMAGNETIC BRAKE MOTOR

■ 90W □ 90mm

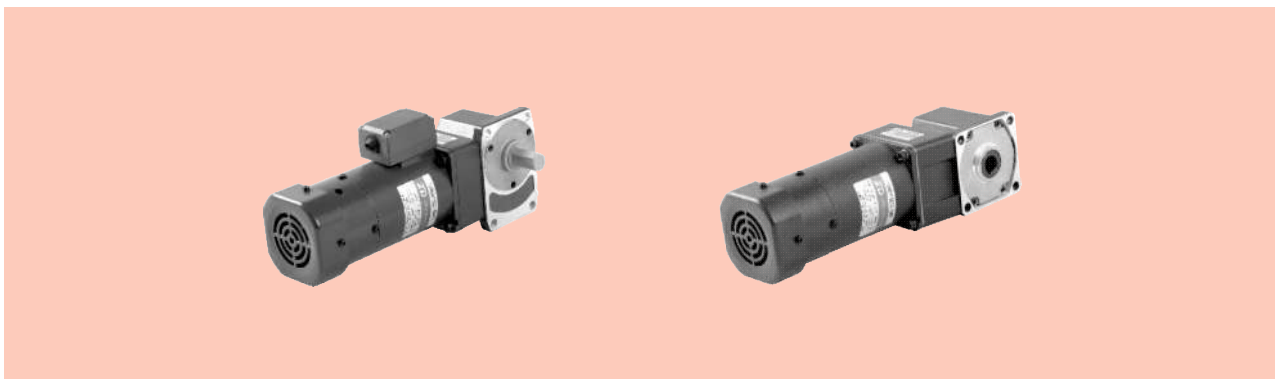

规格 Specs / 电动机 Motor

- 没有内藏简易制动 This type of motor does not contain a built-in simple brake mechanism.

型号 Model · 类型 Type 导线型 Lead Wire Type	额定 Rating	输出功率 Output power	电压 Voltage	频率 Frequency	电流 Current	启动转矩 Starting Torque	额定转矩 Rated Torque	额定转速 Rated Speed	电容器容量 Capacitor
齿轮轴型 Pinion Shaft		W	V	Hz	A	mN.m	mN.m	r/min	μF
5RK90GU-AFM	30min	90	1ph 100	50	1.78	600	700	1250	30
				60	2.35		570	1550	
5RK90GU-EFM	30min	90	1ph 110	60	1.72	550	570	1550	25
			1ph 120			600			
5RK90GU-CFM	30min	90	1ph 220	50	0.82	560	700	1250	6.0
			1ph 230		0.81				
5RK90GU-HFM	30min	90	1ph 220	60	0.81	560	570	1550	
			1ph 230		0.80				
5RK90GU-SFM	30min	90	3ph 220	50	0.60	1350	700	1250	-
				60	0.55	1100	570	1550	

- 各种安全规格以电动机铭牌上的型号取得认定。
When the motor is approved under various safety standards, the model name on the nameplate is the approved model name.
- (T)：此为配件选项，如需要此功能，型号后需带 "P"。
This option for the parts, such as the need for this feature, models need to bring "P".
- 电动机温度下降后会自动恢复运行，故在进行检查作业时请务必事先切断电源。
When the motor temperature drops, the thermal protector closes and the motor restarts. Be sure to turn the motor off before inspecting.
- 注：“-A”型号中电压为110V时，配置电容器容量以实际铭牌为准。
Note: "-A" it means the voltage 110V, the assembly capacitor vaule it is according the labe.

装有减速器时的容许转矩 Gear Motor-Torque Table

- 减速器-中间减速器另售。● 电动机型号的□中为表示带端子箱型的记号(T)。
Gearhead and mid-gearbox can be sold separately. Enter the code that represents the terminal box type (T) in the box (□) within the model name.
- 减速器型号的□中为减速比的数值。□色表示与电动机同一方向运转，其他则为相反方向。
Enter the gear ratio in the box (□) within the model name.
The colored background □ indicates the same rotating direction of the motor while the rotating direction of others are opposite.
- 转速是以电动机的同步转速 (50Hz:1500r/min、60Hz:1800r/min) 为基准除以减速比而算出来的数值。实际转速将随负载大小变化而比所示数值减少2%~20%左右。
The speed is calculated by diving the motor's synchronous speed (50Hz:1500r/min、60Hz:1800r/min) by the gear ratio. The actual speed is 2%~20% less than the displayed value, depending on the size of the load.
- 希望以大于下表的减速比进行进一步减速时，可在电动机与减速器之间安装减速比为10的中间减速器。这时的容许转矩为20N·m。
To reduce the speed beyond the gear ratio in the table, attach a mid-gearbox (gear ratio:10) between the gearhead and motor. In that case, the permissible torque is 20N·m.

弧锥直角 SPIRAL BEVEL RIGHT ANGLE

容许力矩单位 Allowance Torque Unit: 上段 Upside (N.m) / 下段 Belowside (kgf.cm)

机型Type	减速比Gear Ratio	7.5	9	12.5	15	18	25	30	36	50	60	75	90	100	120	150	180		
电动机/减速器 Motor/Gearhead	转速Speed r/min	50Hz	200	166	120	100	83	60	50	41	30	25	20	16	15	12	10	8	
		60Hz	240	200	144	120	100	72	60	50	36	30	24	20	18	15	12	10	
5RK90GU-AF□M 5RK90GU-EF□M 5RK90GU-CF□M 5RK90GU-HF□M 5RK90GU-SF□M	容许力矩 Allowance Torque	50Hz	5GU□RC	3.55	4.26	5.92	7.10	8.52	11.8	14.2	15.3	20.0	20.0	20.0	20.0	20.0	20.0	20.0	
			5GU□RT	36.2	43.5	60.4	72.5	87.0	121	145	157	200	200	200	200	200	200	200	
		60Hz	5GU□RC	2.86	3.44	4.77	5.73	6.87	9.54	11.5	12.4	17.2	20.0	20.0	20.0	20.0	20.0	20.0	20.0
			5GU□RT	29.2	35.1	48.7	58.4	70.1	97.4	117	126	175	200	200	200	200	200	200	200

电机尺寸图 Motor Size Chart

5RK90GU-AF□M/5GU□RC 5RK90GU-CF□M/5GU□RC
5RK90GU-EF□M/5GU□RC 5RK90GU-HF□M/5GU□RC 5RK90GU-SF□M/5GU□RC

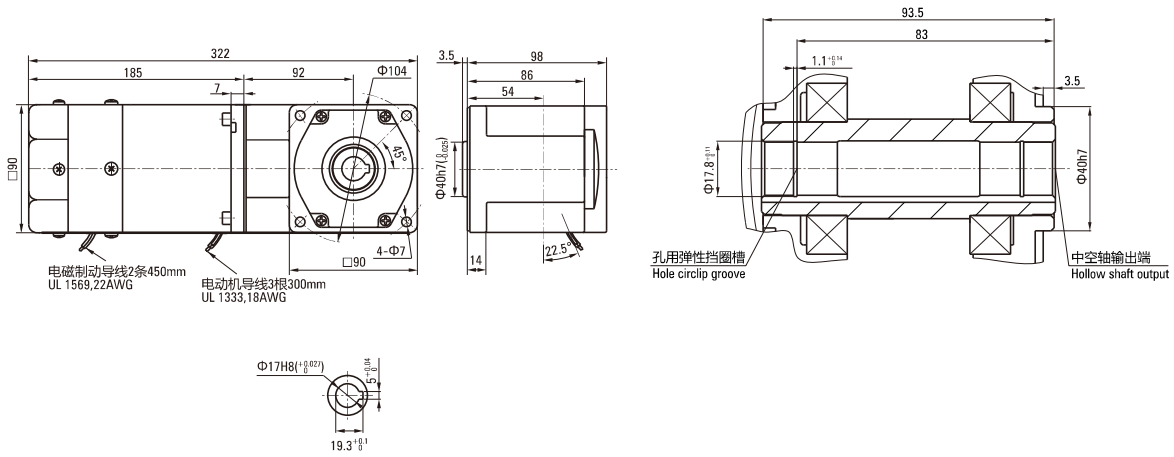

5RK90GU-AF□M/5GU□RT 5RK90GU-CF□M/5GU□RT
5RK90GU-EF□M/5GU□RT 5RK90GU-HF□M/5GU□RT 5RK90GU-SF□M/5GU□RT

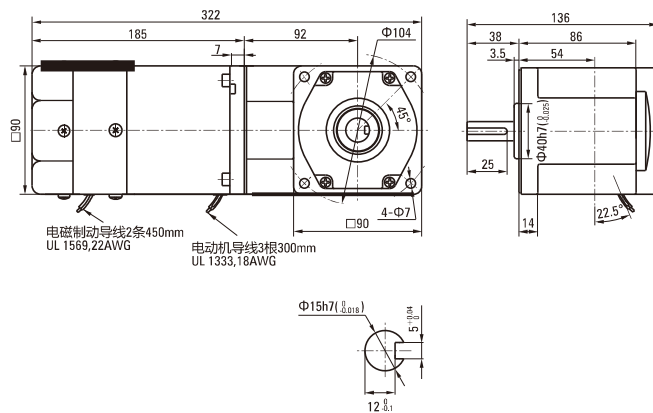

蜗轮蜗杆直角 WORM GEAR RIGHT ANGLE

容许力矩单位 Allowance Torque Unit: 上段 Upside (N.m) / 下段 Belowside (kgf.cm)

机型 Type 电动机/减速器 Motor/Gearhead	减速比 Gear Ratio	7.5	9	12.5	15	18	25	30	36	50	60	75	90	100	120	150	180		
																		转速 Speed r/min	
5RK90GU-AF□M 5RK90GU-EF□M 5RK90GU-CF□M 5RK90GU-HF□M 5RK90GU-SF□M	5GU□RH 5GU□RA	容许力矩 Allowance Torque	50Hz	200	166	120	100	83	60	50	41	30	25	20	16	15	12	10	8
			60Hz	240	200	144	120	100	72	60	50	36	30	24	20	18	15	12	10
			50Hz	2.09	2.51	3.48	4.18	5.01	6.96	8.35	10.0	13.9	16.7	20.0	20.0	20.0	20.0	20.0	20.0
			60Hz	1.68	2.02	2.81	3.37	4.04	5.61	6.74	8.08	11.2	13.5	16.8	20.0	20.0	20.0	20.0	20.0
			60Hz	17.2	20.6	28.6	34.4	41.2	57.3	68.7	82.5	115	137	172	200	200	200	200	200

电机尺寸图 Motor Size Chart

5RK90GU-AF□M/5GU□RH 5RK90GU-CF□M/5GU□RH
5RK90GU-EF□M/5GU□RH 5RK90GU-HF□M/5GU□RH 5RK90GU-SF□M/5GU□RH

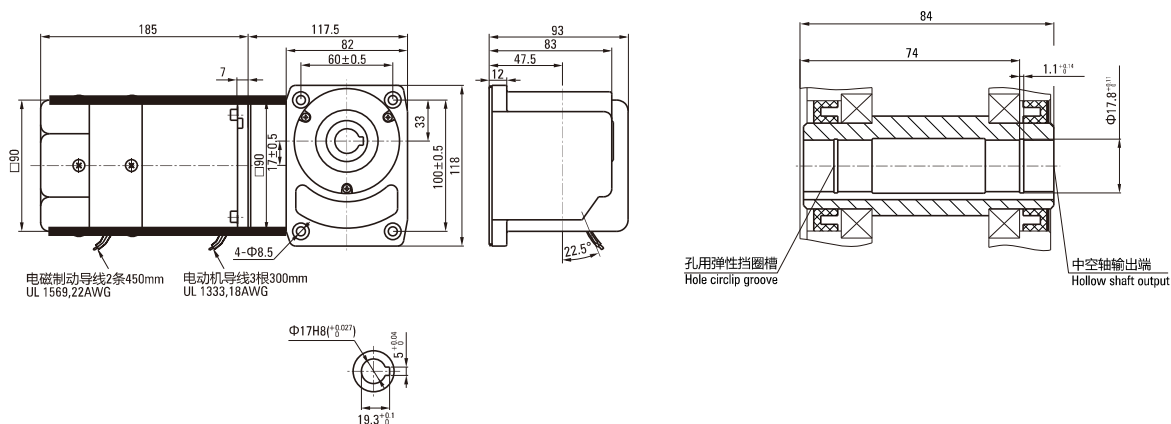

5RK90GU-AF□M/5GU□RA 5RK90GU-CF□M/5GU□RA
5RK90GU-EF□M/5GU□RA 5RK90GU-HF□M/5GU□RA 5RK90GU-SF□M/5GU□RA

