

调速电动机 SPEED ADJUSTABLE MOTOR

■ 60W □ 90mm



规格 Specs 连续额定 Cont. Rated

型号Model · 类型 Type 导线型 Lead Wire Type	最大 输出功率 Output power W	电压 Voltage V	频率 Frequency Hz	调速范围 Speed Control Range r/min	容许转矩 Allowance Torque		启动转矩 Starting Torque mN.m	电流 Current A	电容器容量 Capacitor μF
					1200r/min mN.m	90r/min mN.m			
5IK60RGU-AF 齿轮轴型 Pinion Shaft	60	1ph 100	50	90~1400	460	140	265	1.00	20
			60	90~1700	490	160		1.10	
5IK60RGU-EF	60	1ph 110	60	90~1700	490	160	265	0.80	12
		1ph 120						0.85	
5IK60RGU-CF	60	1ph 220	50	90~1400	490	140	265	0.50	4.0
		1ph 230						0.55	
5IK60RGU-HF	60	1ph 220	60	90~1700	490	160	265	0.50	4.0
		1ph 230						0.55	

- 各种安全规格以电动机铭牌上的型号取得认证。
When the motor is approved under various safety standards, the model name on the nameplate is the approved model name.
- 注：“-A”型号中电压为110V时，配置电容器容量以实际铭牌为准。
Note: "-A" it means the voltage 110V, the assembly capacitor value it is according to the label.

装有减速器时的容许转矩 Gear Motor-Torque Table

- 减速器·中间减速器另售。● 电动机型号的□中为表示带端子箱型的记号(T)。
Gearhead and mid-gearbox can be sold separately. Enter the code that represents the terminal box type (T) in the box (□) within the model name.
- 减速器型号的□中为减速比的数值。□色表示与电动机同一方向运转，其他则为相反方向。
Enter the gear ratio in the box (□) within the model name.
The colored background □ indicates the same rotating direction of the motor while the rotating direction of others are opposite.
- 转速是以电动机的同步转速 (50Hz:1500r/min、60Hz:1800r/min) 为基准除以减速比而算出来的数值。实际转速将随负载大小变化而比所示数值减少2%~20%左右。
The speed is calculated by dividing the motor's synchronous speed (50Hz:1500r/min、60Hz:1800r/min) by the gear ratio. The actual speed is 2%~20% less than the displayed value, depending on the size of the load.
- 希望以大于下表的减速比进行进一步减速时，可在电动机与减速器之间安装减速比为10的中间减速器。这时的容许转矩为20N·m。
To reduce the speed beyond the gear ratio in the table, attach a mid-gearbox (gear ratio:10) between the gearhead and motor. In that case, the permissible torque is 20N·m.

弧锥直角 SPIRAL BEVEL RIGHT ANGLE

容许力矩单位 Allowance Torque Unit: 上段 Upside (N.m) / 下段 Belowside (kgf.cm)

机型 Type		减速比 Gear Ratio	7.5	9	12.5	15	18	25	30	36	50	60	75	90	100	120	150	180	
电动机/减速器 Motor/Gearhead	转速 Speed r/min	50Hz	200	166	120	100	83	60	50	41	30	25	20	16	15	12	10	8	
		60Hz	240	200	144	120	100	72	60	50	36	30	24	20	18	15	12	10	
5IK60RGU-AF□ 5IK60RGU-EF□ 5IK60RGU-CF□ 5IK60RGU-HF□	5GU□RC 5GU□RT	容许力矩 Allowance Torque	50Hz	2.37	2.84	3.95	4.73	5.68	7.89	9.47	10.2	14.2	17.0	20.0	20.0	20.0	20.0	20.0	20.0
			60Hz	19.48	23.37	32.46	38.96	46.75	64.93	77.92	84.1	117	140	175	200	200	200	200	200
		50Hz	24.2	29.0	40.3	48.3	58.0	80.5	96.6	104	145	174	200	200	200	200	200	200	200
		60Hz	19.48	23.37	32.46	38.96	46.75	64.93	77.92	84.1	117	140	175	200	200	200	200	200	200

电机尺寸图 Motor Size Chart

5IK60RGU-AF□/5GU□RC 5IK60RGU-CF□/5GU□RC
5IK60RGU-EF□/5GU□RC 5IK60RGU-HF□/5GU□RC

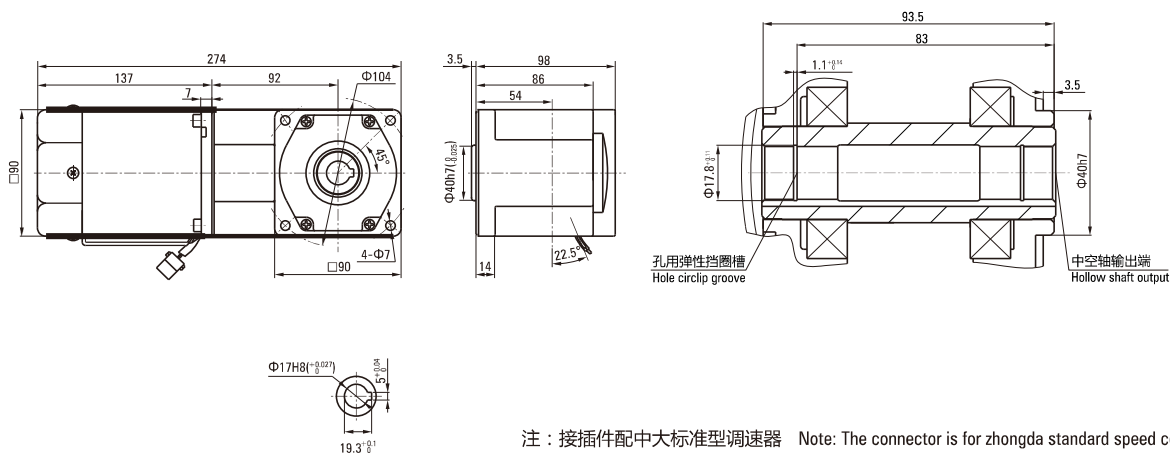

5IK60RGU-AF□/5GU□RT 5IK60RGU-CF□/5GU□RT
5IK60RGU-EF□/5GU□RT 5IK60RGU-HF□/5GU□RT

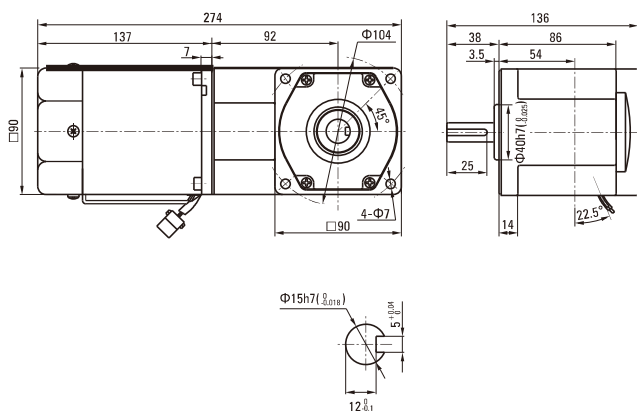

蜗轮蜗杆直角 WORM GEAR RIGHT ANGLE

容许力矩单位 Allowance Torque Unit: 上段 Upside (N.m) / 下段 Belowside (kgf.cm)

机型Type		减速比Gear Ratio	7.5	9	12.5	15	18	25	30	36	50	60	75	90	100	120	150	180	
电动机/减速器 Motor/Gearhead	转速Speed r/min	50Hz	200	166	120	100	83	60	50	41	30	25	20	16	15	12	10	8	
		60Hz	240	200	144	120	100	72	60	50	36	30	24	20	18	15	12	10	
5IK60RGU-AF□ 5IK60RGU-EF□ 5IK60RGU-CF□ 5IK60RGU-HF□	5GU□RH 5GU□RA	容许力矩 Allowance Torque	50Hz	1.39	1.67	2.32	2.78	3.34	4.64	5.57	6.68	9.28	11.1	13.9	16.7	18.6	20.0	20.0	20.0
			60Hz	1.12	1.35	1.87	2.25	2.69	3.74	4.49	5.39	7.49	8.98	11.2	13.5	15.0	18.0	20.0	20.0
		50Hz	14.2	17.0	23.7	28.4	34.1	47.4	56.8	68.2	94.7	114	142	170	189	200	200	200	200
		60Hz	11.5	13.7	19.1	22.9	27.5	38.2	45.8	55.0	76.4	91.7	115	137	153	183	200	200	200

电机尺寸图 Motor Size Chart

5IK60RGU-AF□/5GU□RH 5IK60RGU-CF□/5GU□RH
5IK60RGU-EF□/5GU□RH 5IK60RGU-HF□/5GU□RH

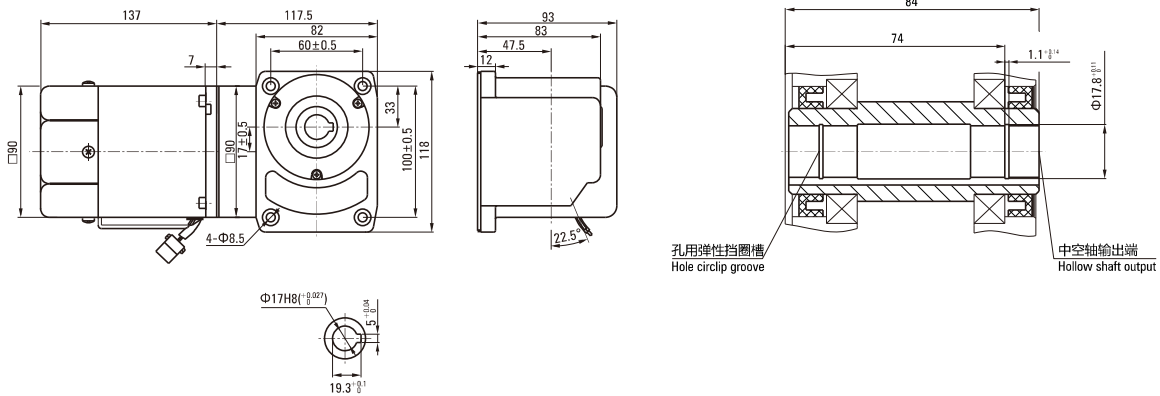

注：接插件配中大标准型调速器 Note: The connector is for zhongda standard speed controller

5IK60RGU-AF□/5GU□RA 5IK60RGU-CF□/5GU□RA
5IK60RGU-EF□/5GU□RA 5IK60RGU-HF□/5GU□RA

