

# 感应电动机 INDUCTION MOTORS

■ 120W □ 104mm

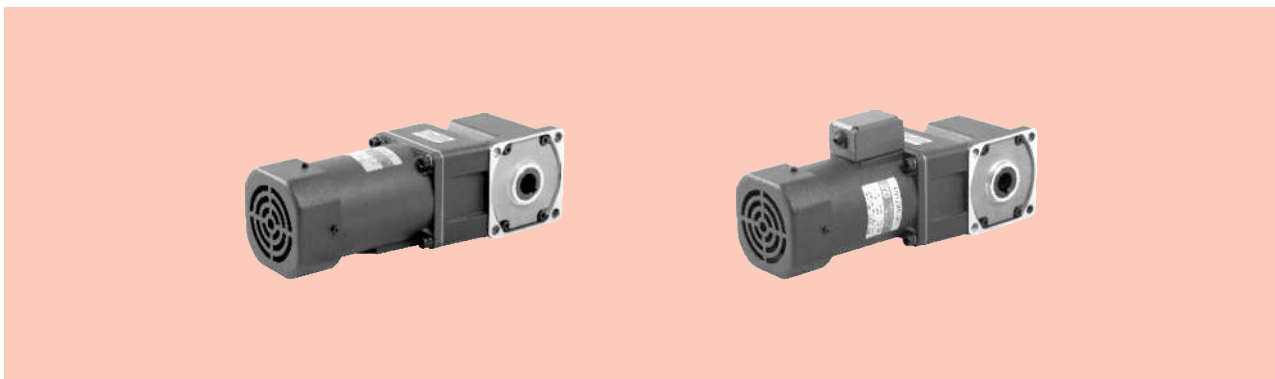

## 规格 Specs 连续额定 Continuous Rating

型号 Model · 类型 Type 上段: 齿轮轴 Upper: Pinion Shaft 下段()内: 圆轴 Below: Round Shaft		输出功率 Output power W	电压 Voltage V	频率 Frequency Hz	电流 Current A	启动转矩 Starting Torque mN.m	额定转矩 Rated Torque mN.m	额定转速 Rated Speed r/min	电容器容量 Capacitor μF
导线型 Lead Wire Type 外形图 Dimensions①	带端子箱型 Terminal Box Type 外形图 Dimensions②								
6IK120GU-AF	6IK120GU-AFT	120	1ph 100	50	2.10	600	930	1250	30
				60	2.50		750	1550	
6IK120GU-EF	6IK120GU-EFT	120	1ph 110 1ph 120	60	1.70	600	750	1550	20
					1.80				
6IK120GU-CF	6IK120GU-CFT	120	1ph 220 1ph 230	50	0.95	750	930	1250	8.0
6IK120GU-SF	6IK120GU-SFT	120	3ph 220	50	0.75	2200	890	1300	
				60	0.70				2000

- 各种安全规格以电动机铭牌上的型号名取得认证。

When the motor is approved under various safety standards, the model name on the nameplate is the approved model name.

- 注：“-A”型号中电压为110V时，配置电容器容量以实际铭牌为准。

Note: "-A" it means the voltage 110V, the assembly capacitor value it is according to the label.

## 装有减速器时的容许转矩 Gear Motor-Torque Table

- 减速器-中间减速器另售。● 电动机型号的□中为表示带端子箱型的记号(T)。

Gearhead and mid-gearbox can be sold separately. Enter the code that represents the terminal box type (T) in the box (□) within the model name.

- 减速器型号的□中为减速比的数值。□色表示与电动机同一方向运转，其他则为相反方向。

Enter the gear ratio in the box (□) within the model name.

The colored background □ indicates the same rotating direction of the motor while the rotating direction of others are opposite.

- 转速是以电动机的同步转速 (50Hz:1500r/min、60Hz:1800r/min) 为基准除以减速比而算出来的数值。实际转速将随负载大小变化而比所示数值减少2%~20%左右。

The speed is calculated by dividing the motor's synchronous speed (50Hz:1500r/min、60Hz:1800r/min) by the gear ratio. The actual speed is 2%~20% less than the displayed value, depending on the size of the load.

- 希望以大于下表的减速比进行进一步减速时，可在电动机与减速器之间安装减速比为10的中间减速器。这时的容许转矩为60N·m。

To reduce the speed beyond the gear ratio in the table, attach a mid-gearbox (gear ratio:10) between the gearhead and motor. In that case, the permissible torque is 60N·m.

# 弧锥直角 SPIRAL BEVEL RIGHT ANGLE

容许力矩单位 Allowance Torque Unit: 上段 Upside (N.m) / 下段 Belowside (kgf.cm)

机型Type 电动机/减速器 Motor/Gearhead	减速比Gear Ratio	转速Speed r/min	7.5	9	12.5	15	18	25	30	36	50	60	75	90	100	120	150	180	
			50Hz	200	166	120	100	83	60	50	42	30	25	20	16	15	12	10	8
60Hz	240	200	144	120	100	72	60	50	36	30	24	20	18	15	12	10			
6IK120GU-AF□ 6IK120GU-EF□ 6IK120GU-CF□ 6IK120GU-HF□ 6IK120GU-SF□	6GU□RC 6GU□RT	容许力矩 Allowance Torque	50Hz	4.26	5.68	7.89	9.47	11.4	15.8	18.9	22.7	28.4	34.1	42.6	51.1	56.8	60.0	60.0	60.0
			60Hz	43.5	58.0	80.5	96.6	116	161	193	232	290	348	435	522	580	600	600	600
		50Hz	3.44	4.58	6.36	7.64	9.16	12.7	15.3	18.3	22.9	27.5	34.4	41.2	45.8	55.0	60.0	60.0	
		60Hz	35.1	46.7	64.9	77.9	93.5	130	156	187	234	280	351	421	467	561	600	600	

## 电机尺寸图 Motor Size Chart

6IK120GU-AF□/6GU□RC 6IK120GU-CF□/6GU□RC  
6IK120GU-EF□/6GU□RC 6IK120GU-HF□/6GU□RC 6IK120GU-SF□/6GU□RC

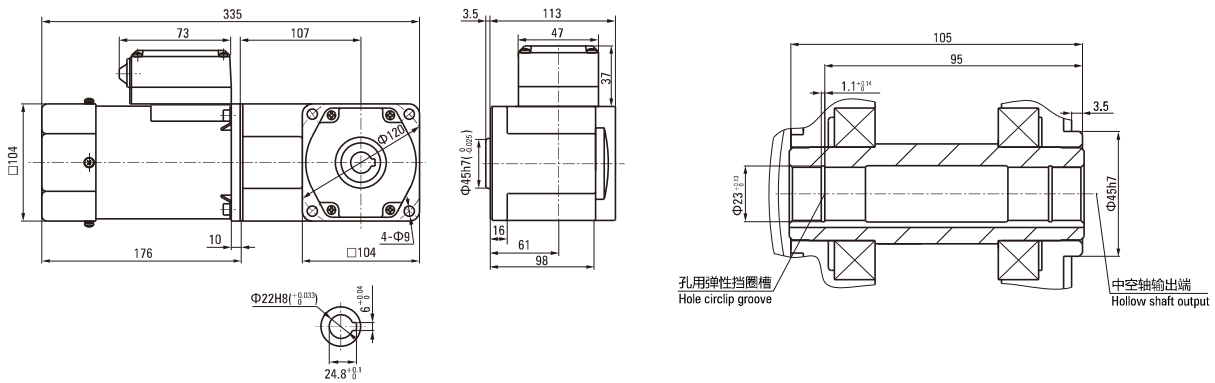

6IK120GU-AF□/6GU□RT 6IK120GU-CF□/6GU□RT  
6IK120GU-EF□/6GU□RT 6IK120GU-HF□/6GU□RT 5IK120GU-SF□/6GU□RT

