

无励磁动作型电磁制动电动机

POWER OFF ACTIVATED TYPE ELECTROMAGNETIC BRAKE MOTOR

■ 120W □ 90mm



■ 规格 Specs / 电动机 Motor

- 没有内藏简易制动 This type of motor does not contain a built-in simple brake mechanism.

型号Model · 类型 Type 导线型 Lead Wire Type		额定 Rating	输出功率 Output power	电压 Voltage	频率 Frequency	电流 Current	启动转矩 Starting Torque	额定转矩 Rated Torque	额定转速 Rated Speed	电容器容量 Capacitor
齿轮轴型 Pinion Shaft	圆轴型 Round Shaft									
5RK120GU-AFM	5RK120A-AFM	30min	120	1ph 100	50	2.25	700	930	1250	35
					60	2.85		750		
5RK120GU-EFM	5RK120A-EFM	30min	120	1ph 110	60	1.90	650	750	1550	30
				1ph 120			720			
5RK120GU-CFM	5RK120A-CFM	30min	120	1ph 220	50	1.15	720	930	1250	8.0
				1ph 230						
5RK120GU-HFM	5RK120A-HFM	30min	120	1ph 220	60	1.20	720	750	1550	-
				1ph 230						
5RK120GU-SFM	5RK120A-SFM	30min	120	3ph 220	50	0.70	1850	930	1250	-
					60	0.60	1600	750	1550	

- 各种安全规格以电动机铭牌上的型号取得认定。
When the motor is approved under various safety standards, the model name on the nameplate is the approved model name.
- (T): 内藏热保护装置 (自动复位型)。在电动机因某种原因过热时会自行启动使电动机停止。
Contains a built-in thermal protector(automatic return). If a motor overheats for any reason, the thermal protector is opened and the motor stops.
- 电动机温度下降后会自行恢复运行，故在进行检查作业时请务必先切断电源。
When the motor temperature drops, the thermal protector closes and the motor restarts. Be sure to turn the motor off before inspecting.
- 注：“-A”型号中电压为110V时，配置电容器容量以实际铭牌为准。
Note:“-A” means the voltage 110V,the assembly capacitor vaule it is according the labe.

■ 种类 Type

- 电动机 Motor

机型 Type	型号Model	
	齿轮轴型 Pinion Shaft	圆轴型 Round Shaft
导线型 Lead Wire Type	5RK120GU-AFM	5RK120A-AFM
	5RK120GU-EFM	5RK120A-EFM
	5RK120GU-CFM	5RK120A-CFM
	5RK120GU-HFM	5RK120A-HFM
	5RK120GU-SFM	5RK120A-SFM

- 平行轴减速器 (另售) Parallel Shaft Gearhead (Sold Separately)

减速器种类 Gearhead Type	减速器型号 Gearhead Model	减速比 Gear Ratio
长寿命●低噪音 Long Life ● Low Noise	5GU□KB	3、3.6、5、6、7.5、9、 12.5、15、18、25、30、 36、50、60、75、90、 100、120、150、180、200
		5GU10XK (中间减速器 Decimal Gearhead)

- 减速器型号的□中为减速比的数值
Enter the gear ratio in the box (□) within the model name

■ 装有减速器时的容许转矩 Gear Motor-Torque Table

- 减速器另售·中间减速器另售。电动机型号的□中为表示带端子箱型的记号(T)。
Gearhead and mid-gearbox can be sold separately. Enter the code that represents the terminal box type (T) in the box (□) within the model name.
- 减速品型号的□中为减速比的数值。
Enter the gear ratio in the box(□) within the model name.
- □色表示与电动机同一方向运转，其他则为相反方向。
The colored background □ indicates the same rotating direction of the motor while the rotating direction of others are opposite.
- 转速是以电动机的同步转速（50Hz：1500r/min、60Hz：1800r/min）为基准除以减速比而算出来的数值。实际转速将随负载大小变化所示数值减少2%~20%左右。
The speed is calculated by dividing the motor's synchronous speed (50Hz：1500r/min、60Hz：1800r/min) by the gear ratio. The actual speed is 2%~20% less than the displayed value, depending on the size of the load.
- 希望以大于下表的减速比进行进一步减速时，可在电动机与减速机之间安装减速比为10的中间减速机。这时的容许转矩为20N·m。
To reduce the speed beyond the gear ratio in the table, attach a decimal gearhead(gear ratio:10)between the gearhead and motor. In that case, the permissible torque is 20 N·m.

■ 容许力矩单位 Allowance Torque Unit：上段 Upside (N.m) /下段 Belowside (kgf.cm)

类型 Type 电动机/减速机 Motor/Gearhead	减速比 Gear Ratio		3	3.6	5	6	7.5	9	12.5	15	18	25	30	36	50	60	75	90	100	120	150	180	200
	转速 Speed r/min	50Hz	500	417	300	250	200	166	120	100	83	60	50	41	30	25	20	16	15	12.5	10	8.3	7.5
		60Hz	600	500	360	300	240	200	144	120	100	72	60	50	36	30	24	20	18	15	12	10	9
5RK120GU-AFM 5RK120GU-EFM 5RK120GU-CFM 5RK120GU-HFM 5RK120GU-SFM	5GU□KB 5GU□K	50Hz	2.3	2.7	3.8	4.5	5.6	6.8	8.5	10.2	12.2	15.3	18.4	20	20	20	20	20	20	20	20	20	20
		60Hz	1.8	2.2	3.0	3.6	4.6	5.5	6.8	8.2	9.8	12.4	14.9	17.8	20	20	20	20	20	20	20	20	20
			50Hz	23.4	27.5	38.7	45.9	57.1	69.3	86.7	104	124	156	187	200	200	200	200	200	200	200	200	200
			60Hz	18.3	22.4	30.6	36.7	46.9	56.1	69.5	83.6	100	126	152	181	200	200	200	200	200	200	200	200

■ 容许悬挂负载·容许轴向负载 To Allow The Hoisting Of The Load Allow Axial Load

电动机 (圆轴型) →272页 Motor(Round Shaft) →P272
减速机 →272页 Gearhead →P272

■ 减速机的容许负载惯性惯量 J Permissible Load Inertia J For Gearhead

→272页 →P272

■ 起动、制动特性 (参考值) Starting And Brake Characteristics(Reference Values)

- 单相电动机 Single-phase Motor
- 三相电动机 Three-phase Motor

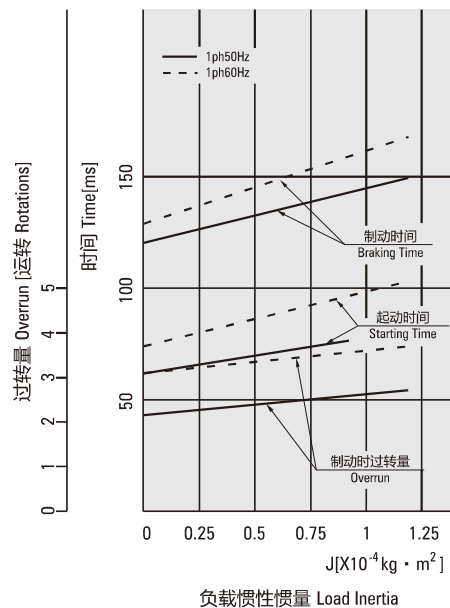
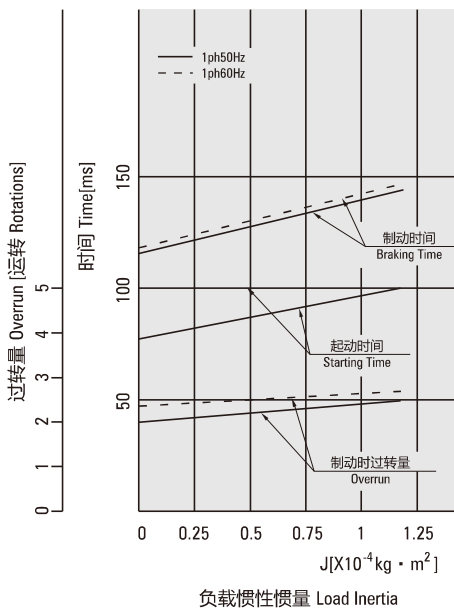

外形图 (单位 mm) Dimensions(Unit mm)

减速器附有安装用螺丝 Mounting screws are included with gearhead.

● 导线型 Lead Wiring Type

重量 Weight : 电动机 Motor : 4.3kg 减速器 Gearhead : 1.5kg

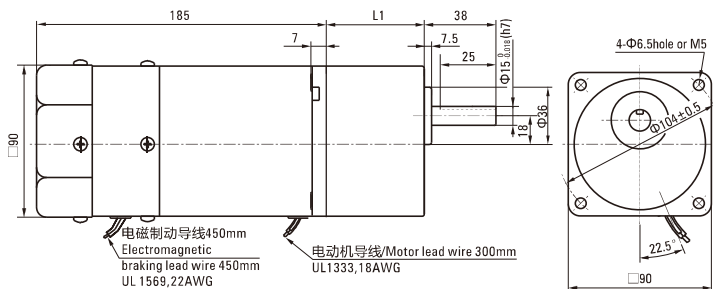

电动机型号 Motor Model	减速器型号 Gearhead Model	减速比 Gear Ratio	L1
5RK120GU-AFM 5RK120GU-EFM 5RK120GU-CFM 5RK120GU-HFM 5RK120GU-SFM	5GU□KB	3~200	65.5

● 减速器型号的□中为减速比的数值
Enter the gear ratio in the box (□) within the model name

● 凸缘安装型减速器 Flange Mounting Reducer

可安装在GU齿轮轴型上
Can be mounted on GU type gear shaft
5GU□K

重量 Weight: 1.5kg

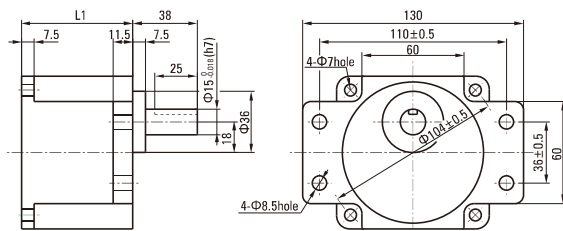

● 键·键槽 (减速器附件)

Key · Keyway (Accessory Of Gearhead)

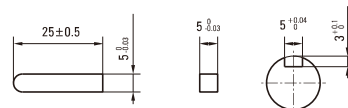

● 圆轴型的转轴部分 Shaft Section Of Round Shaft Type

除重量及轴部外电动机外形与齿轮轴型相同。
Excluding weight and the shaft section motor shape are the same as those of the pinion shaft type.

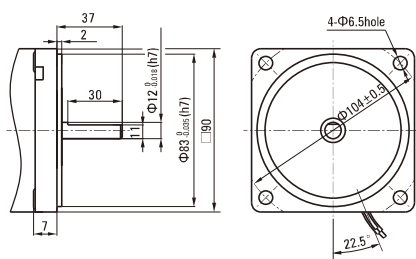

● 中间减速器 Decimal Gearhead

可安装在GU齿轮轴型上 Can be connected to GU pinion shaft type
电动机外形与齿轮轴型相同
5GU10XK

重量 Weight : 0.6kg

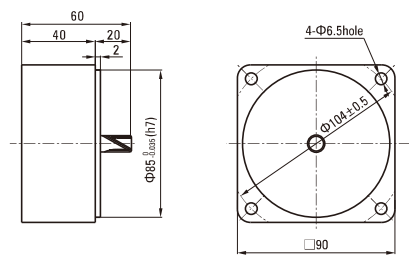

电容器外形尺寸 Formal Dimension Of Capacitor

型号 Model		电容器型号 Capacitor Model	L	W	H
齿轮轴型 Pinion Shaft	圆轴型 Round Shaft				
5RK120GU-AFM	5RK120A-AFM	ZD350CFAUL	58	30	40
5RK120GU-EFM	5RK120A-EFM	ZD300CFAUL	58	26	38
5RK120GU-CFM	5RK120A-CFM	ZD80BFAUL	48	26.5	38

● 常规电容器出线为引线,也可根据客户要求配置插片式187#

Note: Conventional capacitor is a lead wire type. Inserted 187# is optional

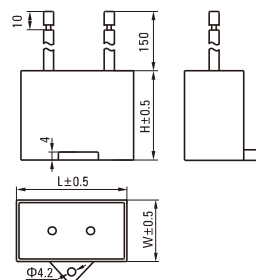

连接图 Wiring Diagram

- 运转方向指从电动机轴看来的方向。CW表示顺时针方向，CCW表示逆时针方向。
The direction of motor rotation is as viewed from the shaft end of motor. CW represents the clockwise direction, while CCW represents the counterclockwise direction.
- 表中所记品名为齿轮轴型，圆轴型亦同。Name indicated in the list is pinion shaft type, also valid for the equivalent round shaft type.

单相电动机 Single-phase Motor

5RK120GU-AFM、5RK120GU-EFM、5RK120GU-CFM、5RK120GU-HFM

SW1为电动机的运行/停止及电磁制动操作作用开关。（连动）

SW1 operates both motor and electromagnetic brake action. (Switched Simultaneously)

SW1设定于ON时，电磁制动解除，电动机开始运行。

The motor will rotate when SW1 is switched simultaneously to ON.

SW1设定于OFF时，电动机停止，电磁制动开始工作。

When SW1 is switched simultaneously to OFF, the motor stops immediately with the electromagnetic brake and holds the load.

在电动机停止状态下解除电磁制动时，应将SW1设定为非连动，而仅将黑色导线侧的触点设定为ON。

If you wish to release the brake while the motor is stopped, set the SW1 to off and connection point at the side of black lead to on.

运转方向。Direction of Rotation.

将SW2转换至CW侧时，电动机作顺时针方向运转。

To rotate the motor in a clockwise (CW) direction, turn SW2 to CW.

将SW2转换至CCW侧时，电动机作逆时针方向运转。

To rotate the motor in a counterclockwise (CCW) direction, turn SW2 to CCW.

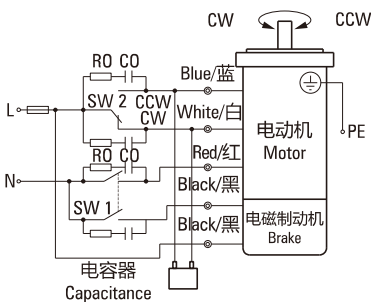

开关 号码 Switch No.	开关的触点容量Capacitor of Switch Connection Point		参考 Note
	单相100V、 110/120V输入 Single-Phase 100 VAC, 110/120 VAC Input	单相220V、 230V输入 Single-Phase 200 VAC, 220/230 VAC Input	
SW1	AC125V 3A以上 (感应负载) 125 VAC 3A minimum (Inductive Load)	AC250V 1.5A以上 (感应负载) 250 VAC 1.5A A minimum (Inductive Load)	连动Switched Simultaneously
SW2			-

三相电动机 Three-phase Motor

5RK120GU-SFM

SW1为电动机的运行/停止及电磁制动操作作用开关。（连动）

SW1 operates both motor and electromagnetic brake action. (Switched Simultaneously)

SW1设定于ON时，电磁制动解除，电动机开始运行。

The motor will rotate when SW1 is switched simultaneously to ON.

SW1设定于OFF时，电动机停止，电磁制动开始工作。

When SW1 is switched simultaneously to OFF, the motor stops immediately with the electromagnetic brake and holds the load.

在电动机停止状态下解除电磁制动时，应将SW1设定为非连动，而仅将黑色导线侧的触点设定为ON。

If you wish to release the brake while the motor is stopped, set the SW1 to off and connection point at the side of black lead to on.

运转方向。Direction of Rotation.

若对换R、S、T中任意二条，电动机作逆时针方向运转。

To change the rotation direction, change any two connections between R, S and T.

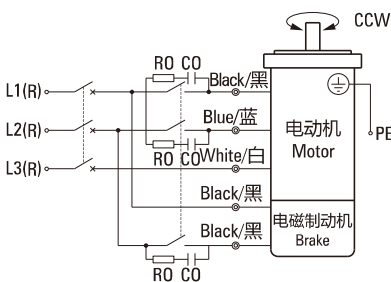

开关 号码 Switch No.	开关的触点容量Capacitor of Switch Connection Point	参考 Note
SW1	AC250V 1.5A以上 (感应负载) 250 VAC 1.5 A minimum (Inductive Load)	连动 Switched Simultaneously

请注意Notes:

- RO CO为吸收电涌电压用CR电路。[R0=5~200Ω、C0=0.1~0.2μF、200WV (400WV)] 请使用选购配件EPCR1201-2。
- R0 and C0 indicate surge suppressor circuit. [R0=5~200Ω, C0=0.1~0.2 μF, 200 WV (400 WV)] EPCR1201-2 is available as an optional surge suppressor.