

无励磁动作型电磁制动电动机

POWER OFF ACTIVATED TYPE ELECTROMAGNETIC BRAKE MOTOR

■ 15W □ 70mm



规格 Specs / 电动机 Motor

- 没有内藏简易制动 This type of motor does not contain a built-in simple brake mechanism.

型号Model · 类型 Type 导线型 Lead Wire Type		额定 Rating	输出功率 Output power	电压 Voltage	频率 Frequency	电流 Current	启动转矩 Starting Torque	额定转矩 Rated Torque	额定转速 Rated Speed	电容器容量 Capacitor
齿轮轴型 Pinion Shaft	圆轴型 Round Shaft									
3RK15GN-AM	3RK15A-AM	30min	15	1ph 100	50	0.40	110	125	1200	7.0
					60	0.56	105	105	1450	
3RK15GN-EM	3RK15A-EM	30min	15	1ph 110	60	0.43	85	105	1450	6.0
				1ph 120		0.42				
3RK15GN-CM	3RK15A-CM	30min	15	1ph 220	50	0.23	110	125	1200	1.5
				1ph 230						
3RK15GN-HM	3RK15A-HM	30min	15	1ph 220	60	0.20	85	105	1450	-
				1ph 230			90			
3RK15GN-SM	3RK15A-SM	30min	15	3ph 220	50	0.14	220	125	1200	-
					60	0.12	180	105	1450	

- 各种安全规格以电动机铭牌上的型号取得认定。

When the motor is approved under various safety standards, the model name on the nameplate is the approved model name.

- (T): 内藏热保护装置 (自动复位型)。在电动机因某种原因过热时会自行启动使电动机停止。
Contains a built-in thermal protector (automatic return). If a motor overheats for any reason, the thermal protector is opened and the motor stops.
- 电动机温度下降后会自动恢复运行，故在进行检查作业时请务必先切断电源。
When the motor temperature drops, the thermal protector closes and the motor restarts. Be sure to turn the motor off before inspecting.
- 注：“-A”型号中电压为110V时，配置电容器容量以实际铭牌为准。
Note:“-A” means the voltage 110v, the assembly capacitor value it is according to the label.

种类 Type

- 电动机 Motor

机型 Type	型号Model	
	齿轮轴型 Pinion Shaft	圆轴型 Round Shaft
导线型 Lead Wire Type	3RK15GN-AM	3RK15A-AM
	3RK15GN-EM	3RK15A-EM
	3RK15GN-CM	3RK15A-CM
	3RK15GN-HM	3RK15A-HM
	3RK15GN-SM	3RK15A-SM

- 平行轴减速器 (另售) Parallel Shaft Gearhead (Sold Separately)

减速器种类 Gearhead Type	减速器型号 Gearhead Model	减速比 Gear Ratio
长寿命●低噪音 Long Life ● Low Noise	3GN□K	3、3.6、5、6、7.5、9、 12.5、15、18、25、30、 36、50、60、75、90、 100、120、150、180、200
	3GN10XK (中间减速器Decimal Gearhead)	

- 减速器型号的□中为减速比的数值
Enter the gear ratio in the box (□) within the model name

■ 装有减速器时的容许转矩 Gear Motor-Torque Table

- 减速器另售·中间减速器另售。
Gearhead and mid-gearbox can be sold separately.
- 减速品型号的□中为减速比的数值。
Enter the gear ratio in the box(□) within the model name.
- □色表示与电动机同一方向运转，其他则为相反方向。
The colored background □ indicates the same rotating direction of the motor while the rotating direction of others are opposite.
- 转速是以电动机的同步转速（50Hz：1500r/min、60Hz：1800r/min）为基准除以减速比而算出来的数值。实际转速将随负载大小变化所示数值减少2%~20%左右。
The speed is calculated by dividing the motor's synchronous speed (50Hz：1500r/min、60Hz：1800r/min) by the gear ratio. The actual speed is 2%~20% less than the displayed value, depending on the size of the load.
- 希望以大于下表的减速比进行进一步减速时，可在电动机与减速机之间安装减速比为10的中间减速器。这时的容许转矩为5N·m。
To reduce the speed beyond the gear ratio in the table, attach a decimal gearhead(gear ratio:10)between the gearhead and motor. In that case, the permissible torque is 5 N·m.

■ 容许力矩单位 Allowance Torque Unit：上段 Upside (N.m) /下段 Belowside (kgf.cm)

类型 Type 电动机/减速机 Motor/Gearhead	减速比 Gear Ratio		3	3.6	5	6	7.5	9	12.5	15	18	25	30	36	50	60	75	90	100	120	150	180	200
	转速 Speed r/min	50Hz	500	417	300	250	200	166	120	100	83	60	50	41	30	25	20	16	15	12.5	10	8.3	7.5
		60Hz	600	500	360	300	240	200	144	120	100	72	60	50	36	30	24	20	18	15	12	10	9
3RK15GN-AM 3RK15GN-EM 3RK15GN-CM 3RK15GN-HM 3RK15GN-SM	3GN□K	50Hz	0.30	0.36	0.51	0.61	0.76	0.91	1.3	1.5	1.8	2.3	2.7	3.3	4.1	5	5	5	5	5	5	5	5
			3.06	3.67	5.20	6.22	7.75	9.28	13.2	15.3	18.3	23.4	27.5	33.7	41.8	50	50	50	50	50	50	50	50
			0.26	0.31	0.43	0.51	0.64	0.77	1.1	1.3	1.5	1.9	2.3	2.8	3.5	4.2	5	5	5	5	5	5	5
		60Hz	2.65	3.16	4.38	5.20	6.53	7.85	11.2	13.2	15.3	19.3	23.4	28.5	35.7	42.8	50	50	50	50	50	50	50
			3.16	3.83	5.20	6.22	7.75	9.28	13.2	15.3	18.3	23.4	27.5	33.7	41.8	50	50	50	50	50	50	50	50
			2.65	3.16	4.38	5.20	6.53	7.85	11.2	13.2	15.3	19.3	23.4	28.5	35.7	42.8	50	50	50	50	50	50	50

■ 容许悬挂负载·容许轴向负载 To Allow The Hoisting Of The Load Allow Axial Load

电动机 (圆轴型) →272页 Motor(Round Shaft) →P272
 减速机 →272页 Gearhead →P272

■ 减速机的容许负载惯性惯量 J Permissible Load Inertia J For Gearhead

→272页 →P272

■ 启动、制动特性 (参考值) Starting And Brake Characteristics(Reference Values)

- 单相电动机 Single-phase Motor
- 三相电动机 Three-phase Motor

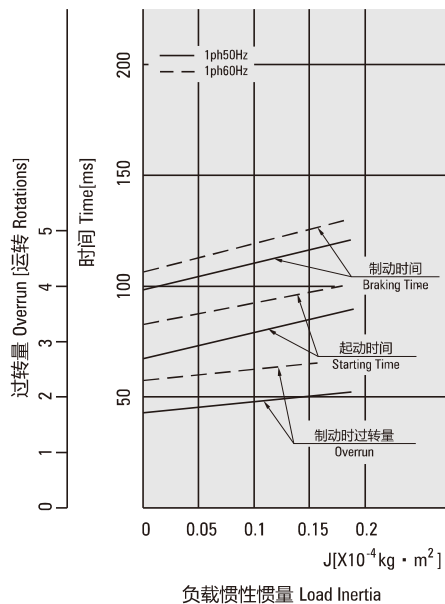
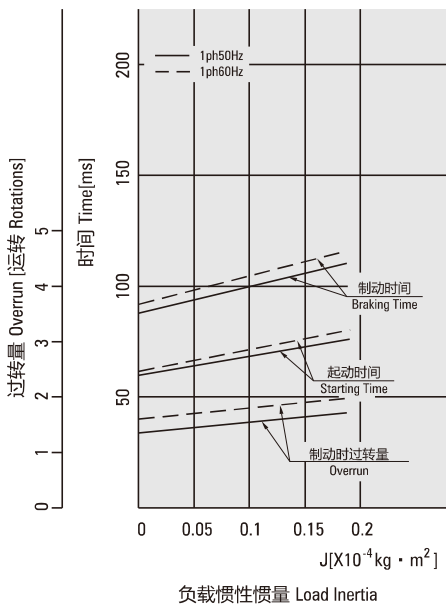

■ 外形图 (单位 mm) Dimensions(Unit mm)

减速器附有安装用螺丝 Mounting screws are included with gearhead.

● 导线型 Lead Wiring Type

重量 Weight : 电动机 Motor : 1.47kg 减速器 Gearhead : 0.5kg

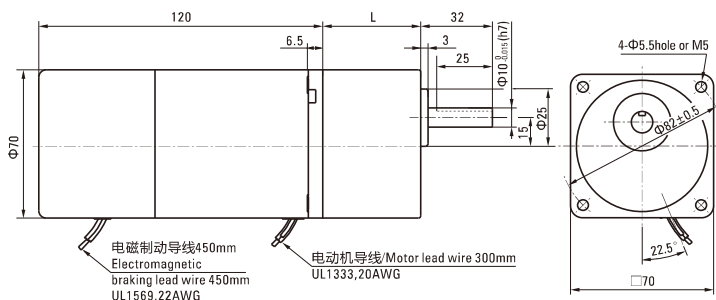

电动机型号 Motor Model	减速器型号 Gearhead Model	减速比 Gear Ratio	L1
3RK15GN-AM	3GN□K	3~18	32
3RK15GN-EM		25~200	42
3RK15GN-CM			
3RK15GN-HM			
3RK15GN-SM			

● 减速器型号的□中为减速比的数值
Enter the gear ratio in the box (□) within the model name

● 键·键槽 (减速器附件) Key·Keyway(Accessory Of Gearhead)

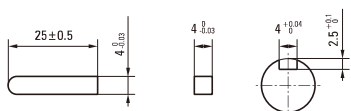

● 圆轴型的转轴部分 Shaft Section Of Round Shaft Type

除重量及轴部外电动机外形与齿轮轴型相同。
Excluding weight and the shaft section motor shape are the same as those of the pinion shaft type.

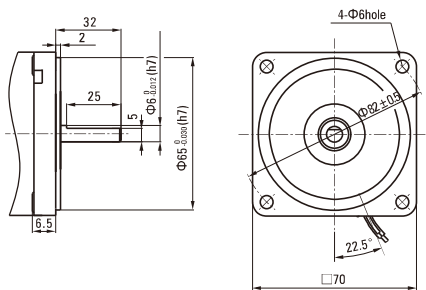

● 中间减速器 Decimal Gearhead

可安装在GN齿轮轴型上 Can be connected to GN pinion shaft type
电动机外形与齿轮轴型相同
3GN10XK
重量 Weight : 0.3kg

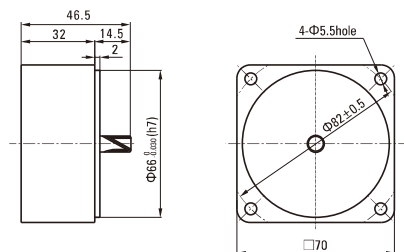

■ 电容器外形尺寸 Formal Dimension Of Capacitor

型号 Model		电容器型号 Capacitor Model	L	W	H
齿轮轴型 Pinion Shaft	圆轴型 Round Shaft				
3RK15GN-AM	3RK15A-AM	ZD70CFAUL	47	24	37
3RK15GN-EM	3RK15A-EM	ZD60CFAUL	48	23	32
3RK15GN-CM	3RK15A-CM	ZD15BFAUL	36	12.5	24

● 常规电容器出线为引线,也可根据客户要求配置插片式187#

Note: Conventional capacitor is a lead wire type. Inserted 187# is optional

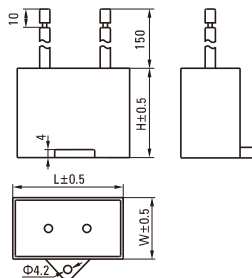

连接图 Wiring Diagram

- 运转方向指从电动机轴看来的方向。CW表示顺时针方向，CCW表示逆时针方向。

The direction of motor rotation is as viewed from the shaft end of motor. CW represents the clockwise direction, while CCW represents the counterclockwise direction.

- 表中所记品名为齿轮轴型，圆轴型亦同。Name indicated in the list is pinion shaft type, also valid for the equivalent round shaft type.

单相电动机 Single-phase Motor

3RK15GN-AM、3RK15GN-EM、3RK15GN-CM、3RK15GN-HM

SW1为电动机的运行/停止及电磁制动操作作用开关。（连动）

SW1 operates both motor and electromagnetic brake action. (Switched Simultaneously)

SW1设定于ON时，电磁制动解除，电动机开始运行。

The motor will rotate when SW1 is switched simultaneously to ON.

SW1设定于OFF时，电动机停止，电磁制动开始工作。

When SW1 is switched simultaneously to OFF, the motor stops immediately with the electromagnetic brake and holds the load.

在电动机停止状态下解除电磁制动时，应将SW1设定为非连动，而仅将黑色导线侧的触点设定为ON。

If you wish to release the brake while the motor is stopped, set the SW1 to off and connection point at the side of black lead to on.

运转方向。Direction of Rotation.

将SW2转换至CW侧时，电动机作顺时针方向运转。

To rotate the motor in a clockwise (CW) direction, turn SW2 to CW.

将SW2转换至CCW侧时，电动机作逆时针方向运转。

To rotate the motor in a counterclockwise (CCW) direction, turn SW2 to CCW.

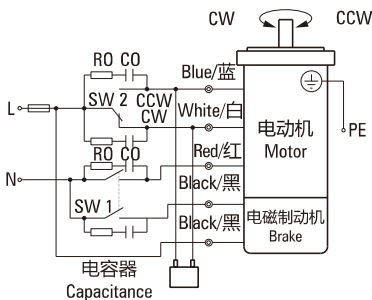

开关 号码 Switch No.	开关的触点容量Capacitor of Switch Connection Point		参考 Note
	单相100V、 110/120V输入 Single-Phase 100 VAC, 110/120 VAC Input	单相220V、 230V输入 Single-Phase 200 VAC, 220/230 VAC Input	
SW1	AC125V 8A以上 (感应负载) 125 VAC 8A minimum (Inductive Load)	AC250V 8A以上 (感应负载) 250 VAC 8A A minimum (Inductive Load)	连动Switched Simultaneously
SW2			-

三相电动机 Three-phase Motor

3RK15GN-SM

SW1为电动机的运行/停止及电磁制动操作作用开关。（连动）

SW1 operates both motor and electromagnetic brake action. (Switched Simultaneously)

SW1设定于ON时，电磁制动解除，电动机开始运行。

The motor will rotate when SW1 is switched simultaneously to ON.

SW1设定于OFF时，电动机停止，电磁制动开始工作。

When SW1 is switched simultaneously to OFF, the motor stops immediately with the electromagnetic brake and holds the load.

在电动机停止状态下解除电磁制动时，应将SW1设定为非连动，而仅将黑色导线侧的触点设定为ON。

If you wish to release the brake while the motor is stopped, set the SW1 to off and connection point at the side of black lead to on.

运转方向。Direction of Rotation.

若对换R、S、T中任意二条，电动机作逆时针方向运转。

To change the rotation direction, change any two connections between R, S and T.

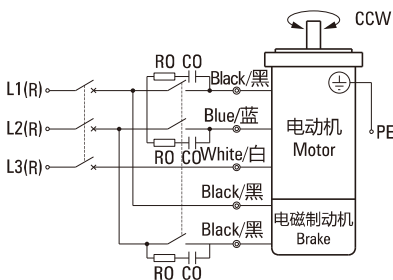

开关 号码 Switch No.	开关的触点容量Capacitor of Switch Connection Point	参考 Note
SW1	AC250V 1.5A以上 (感应负载) 250 VAC 1.5 A minimum (Inductive Load)	连动 Switched Simultaneously

请注意Notes:

- ROCO为吸收电涌电压用CR电路。[R0=5~200Ω、C0=0.1~0.2μF、200WV(400WV)] 请使用选购配件EPCR1201-2。

- RO and CO indicate surge suppressor circuit. [R0=5~200Ω, C0=0.1~0.2 μF, 200 WV (400 WV)] EPCR1201-2 is available as an optional surge suppressor.