

可逆电动机 REVERSIBLE MOTORS

■ 40W □ 90mm

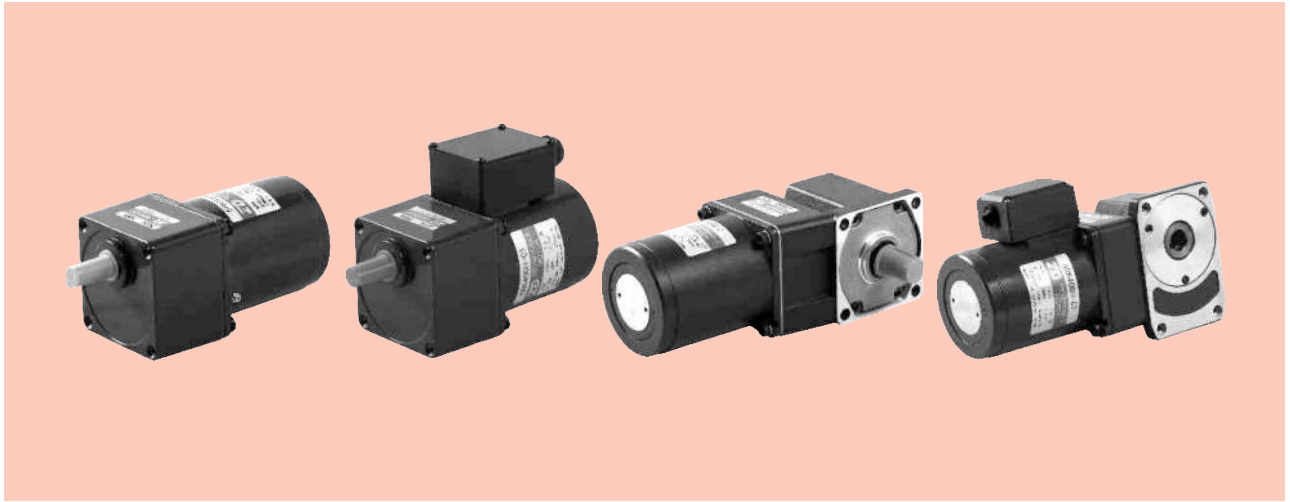

规格 Specs 30分钟额定 30 Minutes Rating

型号Model · 类型 Type 上段: 齿轮轴 Upper: Pinion Shaft 下段()内: 圆轴 Below: Round Shaft		输出功率 Output power W	电压 Voltage V	频率 Frequency Hz	电流 Current A	启动转矩 Starting Torque mN.m	额定转矩 Rated Torque mN.m	额定转速 Rated Speed r/min	电容器容量 Capacitor μF
导线型 Lead Wire Type 外形图Dimensions①	带端子箱型 Terminal Box Type 外形图Dimensions②								
5RK40GN-A (5RK40A-A)	5RK40GN-AT (5RK40A-AT)	40	1ph 100	50	0.78	300	315	1250	15.0
				60	1.05		260	1550	
5RK40GN-E (5RK40A-E)	5RK40GN-ET (5RK40A-ET)	40	1ph 110 1ph 120	60	0.79	260	260	1550	12.0
					0.80				
5RK40GN-C (5RK40A-C)	5RK40GN-CT (5RK40A-CT)	40	1ph 220 1ph 230	50	0.45	270	315	1250	3
5RK40GN-H (5RK40A-H)	5RK40GN-HT (5RK40A-HT)	40	1ph 220 1ph 230	60	0.45	270	260	1550	3

- 各种安全规格以电动机铭牌上的型号名取得认证。
When the motor is approved under various safety standards, the model name on the nameplate is the approved model name.
- 注:“-A”型号中电压为110V时,配置电容器容量以实际铭牌为准。
Note:“-A” it means the voltage 110v, the assembly capacitor value it is according to the label.

种类 Type

- 电动机 Motor

机型 Type	型号Model	
	齿轮轴型 Pinion Shaft	圆轴型 Round Shaft
导线型 Lead Wire Type	5RK40GN-A	5RK40A-A
	5RK40GN-E	5RK40A-E
	5RK40GN-C	5RK40A-C
	5RK40GN-H	5RK40A-H
带端子箱型 Terminal Box Type	5RK40GN-AT	5RK40A-AT
	5RK40GN-ET	5RK40A-ET
	5RK40GN-CT	5RK40A-CT
	5RK40GN-HT	5RK40A-HT

- 平行轴减速器 (另售) Parallel Shaft Gearhead (Sold Separately)

减速器种类 Gearhead Type	减速器型号 Gearhead Model	减速比 Gear Ratio
长寿命●低噪音 Long Life ● Low Noise	5GN□K	3、3.6、5、6、7.5、9、12.5、15、18、25、30、36、50、60、75、90、100、120、150、180、200
	5GN10XK (中间减速器 Decimal Gearhead)	

- 减速器型号的□中为减速比的数值
Enter the gear ratio in the box (□) within the model name

■ 装有减速器时的容许转矩 Gear Motor-Torque Table

- 减速器另售·中间减速器另售。电动机型号的□中为表示带端子箱型的记号(T)。
Gearhead and mid-gearbox can be sold separately. Enter the code that represents the terminal box type (T) in the box (□) within the model name.
- 减速品型号的□中为减速比的数值。
Enter the gear ratio in the box(□) within the model name.
- □色表示与电动机同一方向运转，其他则为相反方向。
The colored background □ indicates the same rotating direction of the motor while the rotating direction of others are opposite.
- 转速是以电动机的同步转速(50Hz:1500r/min、60Hz:1800r/min)为基准除以减速比而算出来的数值。实际转速将随负载大小变化所示数值减少2%~20%左右。
The speed is calculated by dividing the motor's synchronous speed(50Hz:1500r/min、60Hz:1800r/min) by the gear ratio. The actual speed is 2%~20% less than the displayed value, depending on the size of the load.
- 希望以大于下表的减速比进行进一步减速时，可在电动机与减速机之间安装减速比为10的中间减速机。这时的容许转矩为8N·m。
To reduce the speed beyond the gear ratio in the table, attach a decimal gearhead(gear ratio:10)between the gearhead and motor. In that case, the permissible torque is 8N·m.

■ 容许力矩单位 Allowance Torque Unit : 上段 Upside (N.m) /下段 Belowside (kgf.cm)

类型 Type 电动机/减速机 Motor/Gearhead	减速比 Gear Ratio		3	3.6	5	6	7.5	9	12.5	15	18	25	30	36	50	60	75	90	100	120	150	180	200	
	转速 Speed r/min	50Hz	500	417	300	250	200	166	120	100	83	60	50	41	30	25	20	16	15	12.5	10	8.3	7.5	
5RK40GN-A□ 5RK40GN-E□ 5RK40GN-C□ 5RK40GN-H□	5GN□K	60Hz	600	500	360	300	240	200	144	120	100	72	60	50	36	30	24	20	18	15	12	10	9	
		50Hz	0.77	0.92	1.3	1.5	1.9	2.3	3.2	3.8	4.6	5.7	6.9	8.3	10	10	10	10	10	10	10	10	10	10
	5GN□K	60Hz	7.85	9.38	13.2	15.3	19.4	23.4	32.6	38.7	46.9	58.1	70.4	84.7	100	100	100	100	100	100	100	100	100	100
		50Hz	0.63	0.76	1.1	1.3	1.6	1.9	2.6	3.2	3.8	4.7	5.7	6.8	8.6	10	10	10	10	10	10	10	10	10
		60Hz	6.42	7.75	11.2	13.2	16.3	19.3	26.5	32.6	38.7	47.9	58.1	69.3	87.7	100	100	100	100	100	100	100	100	

■ 容许悬挂负载·容许轴向负载 To Allow The Hoisting Of The Load Allow Axial Load

电动机(圆轴型)→P272页

Motor(Round Shaft)→P272

减速机→P272页

Gearhead→P272

■ 减速机的容许负载惯性惯量 J Permissible Load Inertia J For Gearhead

→P272页→P272

■ 外形图(单位 mm) Dimensions(Unit mm)

减速机附有安装用螺丝Mounting screws are included with gearhead.

● 导线型 Lead Wiring Type ①

重量 Weight : 电动机 Motor : 1.65kg

减速机 Gearhead : 0.8kg

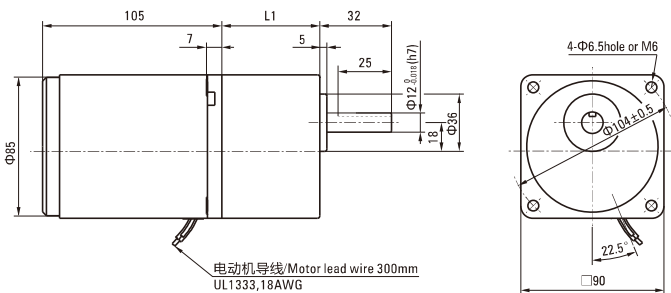

电动机型号 Motor Model	减速器型号 Gearhead Model	减速比 Gear Ratio	L1
5RK40GN-A	5GN□K	3~18	42
5RK40GN-E		25~200	60
5RK40GN-C			
5RK40GN-H			

- 减速器型号的□中为减速比的数值
Enter the gear ratio in the box (□) within the model name

● 带端子箱型 Terminal Box Type ②

重量 Weight : 电动机 Motor : 2.6kg

减速器 Gearhead : 1.35kg

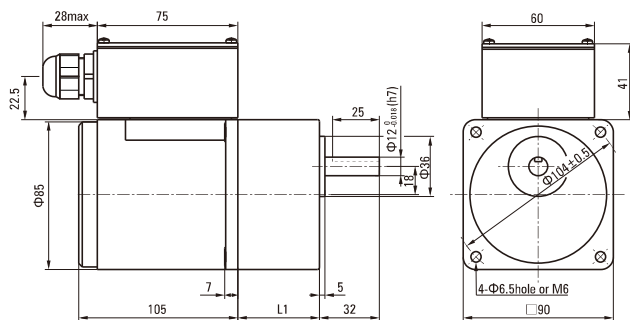

● 适用电缆直径为 Use cable with a diameter of $\Phi 6 \sim \Phi 12$ mm

● 键 · 键槽 (减速器附件) Key · Keyway(Accessory Of Gearhead)

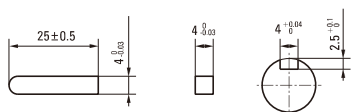

● 圆轴型的转轴部分 Shaft Section Of Round Shaft Type

除重量及轴部外电动机外形与齿轮轴型相同。
Excluding weight and the shaft section motor shape are the same as those of the pinion shaft type.

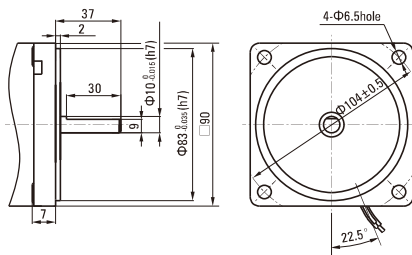

电动机型号 Motor Model	减速器型号 Gearhead Model	减速比 Gear Ratio	L1
5RK40GN-AT 5RK40GN-ET 5RK40GN-CT 5RK40GN-HT	5GN□K	3~18 25~200	42 60

● 减速器型号的□中为减速比的数值
Enter the gear ratio in the box (□) within the model name

● 中间减速器 Decimal Gearhead

可安装在GN齿轮轴型上 Can be connected to GN pinion shaft type
电动机外形与齿轮轴型相同

5GN10XK

重量 Weight : 0.6kg

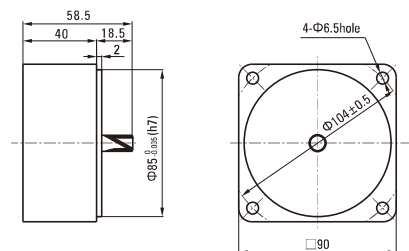

■ 电容器外形尺寸 Formal Dimension Of Capacitor

型号 Model		电容器型号 Capacitor Model	L	W	H
齿轮轴型 Pinion Shaft	圆轴型 Round Shaft				
5RK40GN-A	5RK40A-A	ZD150CFAUL	58	23	43
5RK40GN-E	5RK40A-E	ZD120CFAUL	58	30	40
5RK40GN-C	5RK40A-C	ZD30BFAUL	38	18.5	29

● 常规电容器出线为引线,也可根据客户要求配置插片式187#

Note: Conventional capacitor is a lead wire type. Inserted 187# is optional

● 电动机型号的□中为表示带端子箱型的记号(T)

Enter the code that represents the terminal box type (T) in the box (□) within the model name

