

可逆电动机 REVERSIBLE MOTORS

■ 25W □ 80mm

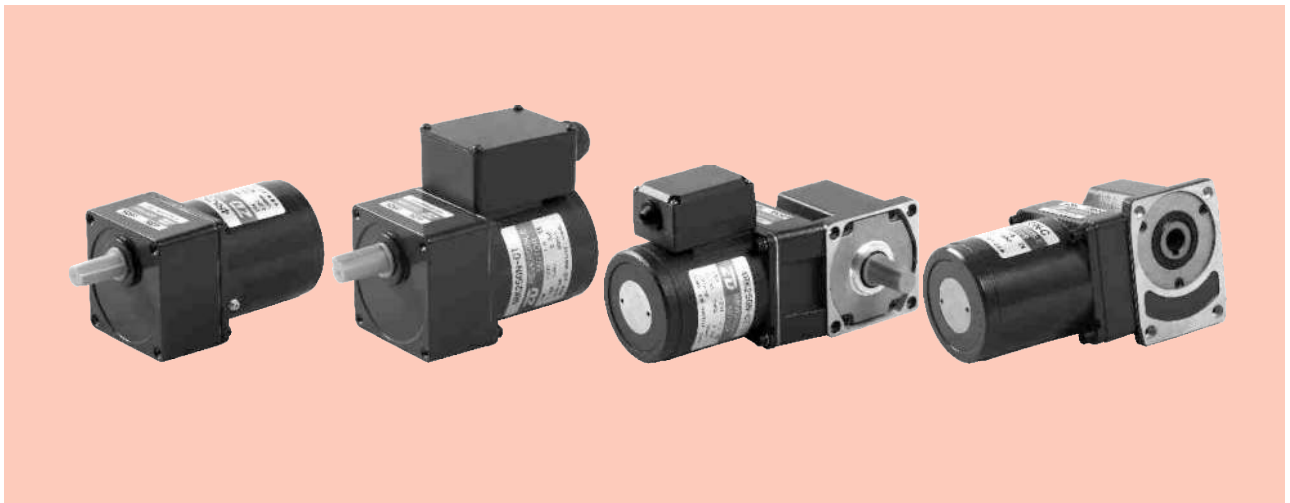

规格 Specs 30分钟额定 30 Minutes Rating

型号 Model · 类型 Type		输出功率 Output power W	电压 Voltage V	频率 Frequency Hz	电流 Current A	启动转矩 Starting Torque mN.m	额定转矩 Rated Torque mN.m	额定转速 Rated Speed r/min	电容器容量 Capacitor μF
上段:齿轮轴 Upper:Pinion Shaft 下段()内:圆轴 Below:Round Shaft	导线型 Lead Wire Type 外形图Dimensions①								
4RK25GN-A (4RK25A-A)	4RK25GN-AT (4RK25A-AT)	25	1ph 100	50	0.59	160	200	1250	10.0
				60	0.69	140	165	1550	
4RK25GN-E (4RK25A-E)	4RK25GN-ET (4RK25A-ET)	25	1ph 110 1ph 120	60	0.45	140	165	1550	8.0
					0.50				
4RK25GN-C (4RK25A-C)	4RK25GN-CT (4RK25A-CT)	25	1ph 220 1ph 230	50	0.29	140	200	1250	2.2
					0.30				
4RK25GN-H (4RK25A-H)	4RK25GN-HT (4RK25A-HT)	25	1ph 220 1ph 230	60	0.35	140	165	1550	2.2

- 可逆电动机的额定转矩、启动转矩数值均为未安装简易制动时的数值。
Values shown for rated torque and starting torque are measured for operation without the friction brake installed.
- 各种安全规格以电动机铭牌上的型号取得认定。
When the motor is approved under various safety standards, the model name on the nameplate is the approved model name.
- Ⓧ : 内置热保护装置(自动复位型)。在电动机因某种原因过热时会自行启动使电动机停止。
Contains a built-in thermal protector(automatic return). If a motor overheats for any reason, the thermal protector is opened and the motor stops.
- 电动机温度下降后会自动恢复运行,故在进行检查作业时请务必先切断电源。
When the motor temperature drops, the thermal protector closes and the motor restarts. Be sure to turn the motor off before inspecting.
- 注:“-A”型号中电压为110V时,配置电容器容量以实际铭牌为准。
Note:“-A” it means the voltage 110v,the assembly capacitor vaule it is according the labe.

种类 Type

● 电动机 Motor

机型 Type	型号 Model	
	齿轮轴型 Pinion Shaft	圆轴型 Round Shaft
导线型 Lead Wire Type	4RK25GN-A	4RK25A-A
	4RK25GN-E	4RK25A-E
	4RK25GN-C	4RK25A-C
	4RK25GN-H	4RK25A-H
带端子箱型 Terminal Box Type	4RK25GN-AT	4RK25A-AT
	4RK25GN-ET	4RK25A-ET
	4RK25GN-CT	4RK25A-CT
	4RK25GN-HT	4RK25A-HT

● 平行轴减速器(另售) Parallel Shaft Gearhead (Sold Separately)

减速器种类 Gearhead Type	减速器型号 Gearhead Model	减速比 Gear Ratio
长寿命●低噪音 Long Life ● Low Noise	4GN□K	3、3.6、5、6、7.5、9、 12.5、15、18、25、30、 36、50、60、75、90、 100、120、150、180、200
	4GN10XK (中间减速器 Decimal Gearhead)	

- 减速器型号的□中为减速比的数值
Enter the gear ratio in the box (□) within the model name

装有减速器时的容许转矩 Gear Motor-Torque Table

- 减速器另售·中间减速器另售。电动机型号的□中为表示带端子箱型的记号(T)。
Gearhead and mid-gearbox can be sold separately. Enter the code that represents the terminal box type (T) in the box (□) within the model name.
- 减速品型号的□中为减速比的数值。
Enter the gear ratio in the box(□) within the model name.
- 色表示与电动机同一方向运转，其他则为相反方向。
The colored background □ indicates the same rotating direction of the motor while the rotating direction of others are opposite.
- 转速是以电动机的同步转速(50Hz:1500r/min、60Hz:1800r/min)为基准除以减速比而算出来的数值。实际转速将随负载大小变化所示数值减少2%~20%左右。
The speed is calculated by dividing the motor's synchronous speed(50Hz:1500r/min、60Hz:1800r/min) by the gear ratio. The actual speed is 2%~20% less than the displayed value, depending on the size of the load.
- 希望以大于下表的减速比进行进一步减速时，可在电动机与减速机之间安装减速比为10的中间减速机。这时的容许转矩为8N·m。但安装了1/25~1/36的减速器时，容许转矩为6N·m
To reduce the speed beyond the gear ratio in the table, attach a decimal gearhead(gear ratio:10)between the gearhead and motor. In that case, the permissible torque is 8N·m. When a gearhead of 1/25~1/36 is connected, the value for permissible torque is 6N·m.

容许力矩单位 Allowance Torque Unit : 上段 Upside (N.m) /下段 Belowside (kgf.cm)

类型 Type 电动机/减速机 Motor/Gearhead	减速比 Gear Ratio		3	3.6	5	6	7.5	9	12.5	15	18	25	30	36	50	60	75	90	100	120	150	180	200
	转速 Speed r/min	50Hz	500	417	300	250	200	166	120	100	83	60	50	41	30	25	20	16	15	12.5	10	8.3	7.5
		60Hz	600	500	360	300	240	200	144	120	100	72	60	50	36	30	24	20	18	15	12	10	9
4RK25GN-A□ 4RK25GN-E□ 4RK25GN-C□ 4RK25GN-H□	4GN□K	50Hz	0.49	0.58	0.81	0.97	1.2	1.5	2.0	2.4	2.9	3.7	4.4	5.3	6.6	7.9	8	8	8	8	8	8	8
			5.00	5.91	8.26	9.89	12.2	15.3	20.4	24.4	29.6	37.7	44.9	54.1	67.3	80	80	80	80	80	80	80	80
		60Hz	0.40	0.48	0.67	0.80	1.0	1.2	1.7	2.0	2.4	3.0	3.6	4.3	5.4	6.5	8	8	8	8	8	8	8
			4.08	4.89	6.83	8.16	10.2	12.2	17.3	20.4	24.4	30.6	36.7	43.8	55.1	66.3	80	80	80	80	80	80	80

容许悬挂负载·容许轴向负载 To Allow The Hoisting Of The Load Allow Axial Load

电动机(圆轴型)→P272页 Motor(Round Shaft)→P272
减速机→P272页 Gearhead→P272

减速机的容许负载惯性惯量 J Permissible Load Inertia J For Gearhead

→P272页→P272

外形图(单位 mm) Dimensions(Unit mm)

减速机附有安装用螺丝Mounting screws are included with gearhead.

● 导线型 Lead Wiring Type ①

重量 Weight : 电动机 Motor : 1.65kg 减速机 Gearhead : 0.8kg

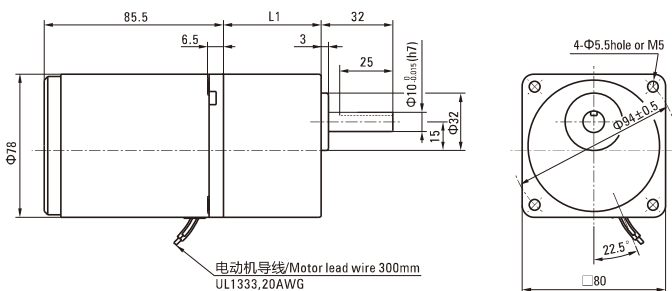

电动机型号 Motor Model	减速机型号 Gearhead Model	减速比 Gear Ratio	L1
4RK25GN-A 4RK25GN-E 4RK25GN-C	4GN□K	3~18	32
4RK25GN-H		25~200	43.5

- 减速机型号的□中为减速比的数值
Enter the gear ratio in the box (□) within the model name

连接图 Wiring Diagram

- 运转方向指从电动机轴看来的方向。CW表示顺时针方向，CCW表示逆时针方向。
The direction of motor rotation is as viewed from the shaft end of motor. CW represents the clockwise direction, while CCW represents the counterclockwise direction.
- 表中所记品名为齿轮轴型，圆轴型亦同。
Name indicated in the list is pinion shaft type, also valid for the equivalent round shaft type.

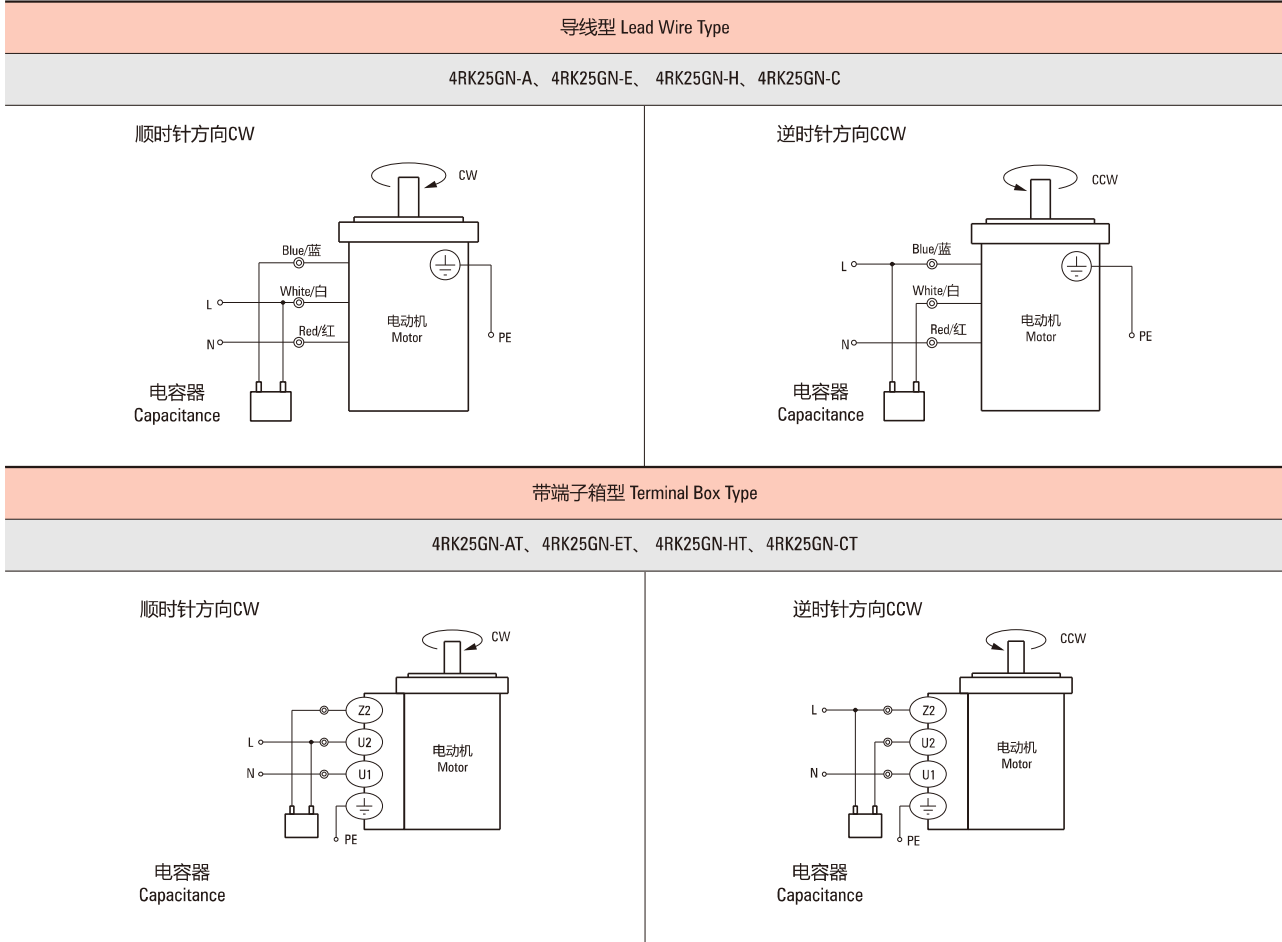

请注意 Note:

单相电动机运转方向的转换应在电动机停止后进行。

Change the direction of single-phase motor rotation only after bring the motor to a stop.

若在电动机运转时转换运转方向，可能发生无法转换运转方向或须费时较久的情况。

If an attempt is made to change the direction of rotation while the motor is rotating, motor may ignore reversing command or change its direction of rotation after some delay.