

感应电动机 INDUCTION MOTORS

■ 60W □ 90mm

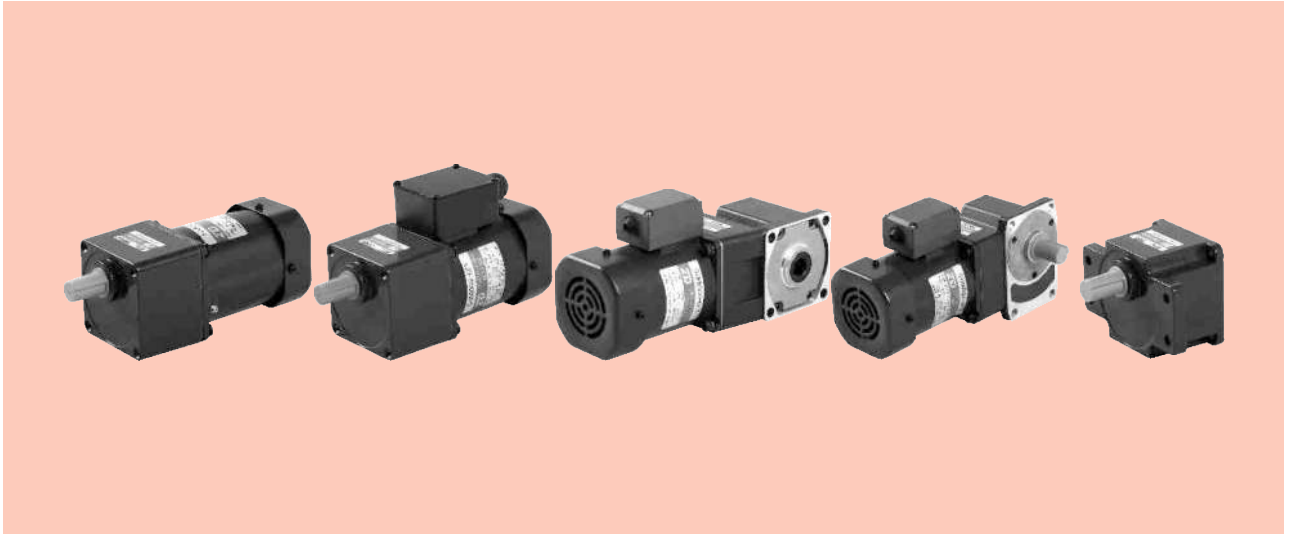

规格 Specs 连续额定 Continuous Rating

型号Model · 类型 Type 上段:齿轮轴 Upper:Pinion Shaft 下段():内:圆轴 Below:Round Shaft		输出功率 Output power W	电压 Voltage V	频率 Frequency Hz	电流 Current A	启动转矩 Starting Torque mN.m	额定转矩 Rated Torque mN.m	额定转速 Rated Speed r/min	电容器容量 Capacitor μF
导线型 Lead Wire Type 外形图Dimensions①	带端子箱型 Terminal Box Type 外形图Dimensions②								
5IK60GU-AF	5IK60GU-AFT	60	1ph 100	50	1.00	320	470	1250	20.0
				60	1.10		380	1550	
5IK60GU-EF	5IK60GU-EFT	60	1ph 110 1ph 120	60	0.80	300	380	1550	12.0
					0.85				
5IK60GU-CF	5IK60GU-CFT	60	1ph 220 1ph 230	50	0.50	340	470	1250	4.0
					0.55				
5IK60GU-HF	5IK60GU-HFT	60	1ph 220 1ph 230	60	0.50	340	380	1550	-
					0.55				
5IK60GU-SF	5IK60GU-SFT	60	3ph 220	50	0.45	1000	470	1250	-
				60	0.40	800	380	1550	

●各种安全规格以电动机铭牌上的型号名取得认证。

When the motor is approved under various safety standards, the model name on the nameplate is the approved model name.

●注：“-A”型号中电压为110V时，配置电容器容量以实际铭牌为准。

Note:“-A” it means the voltage 110V,the assembly capacitor vaule it is according the labe.

种类 Type

● 电动机 Motor

机型 Type	型号Model
	齿轮轴型 Pinion Shaft
导线型 Lead Wire Type	5IK60GU-AF
	5IK60GU-EF
	5IK60GU-CF
	5IK60GU-HF
	5IK60GU-SF
带端子箱型 Terminal Box Type	5IK60GU-AFT
	5IK60GU-EFT
	5IK60GU-CFT
	5IK60GU-HFT
	5IK60GU-SFT

● 平行轴减速器（另售） Parallel Shaft Gearhead (Sold Separately)

减速器种类 Gearhead Type	减速器型号 Gearhead Model	减速比 Gear Ratio
长寿命●低噪音 Long Life ● Low Noise	5GU□KB	3、3.6、5、6、7.5、9、12.5、15、18、25、30、36、50、60、75、90、100、120、150、180、200
	5GU10XK (中间减速器 Decimal Gearhead)	

●减速器型号的□中为减速比的数值

Enter the gear ratio in the box (□) within the model name

装有减速器时的容许转矩 Gear Motor-Torque Table

- 减速器另售·中间减速器另售。电动机型号的□中为表示带端子箱型的记号(T)。
Gearhead and mid-gearbox can be sold separately. Enter the code that represents the terminal box type (T) in the box (□) within the model name.
- 减速品型号的□中为减速比的数值。
Enter the gear ratio in the box(□) within the model name.
- □色表示与电动机同一方向运转，其他则为相反方向。
The colored background □ indicates the same rotating direction of the motor while the rotating direction of others are opposite.
- 转速是以电动机的同步转速(50Hz:1500r/min、60Hz:1800r/min)为基准除以减速比而算出来的数值。实际转速将随负载大小变化所示数值减少2%~20%左右。
The speed is calculated by dividing the motor's synchronous speed(50Hz:1500r/min、60Hz:1800r/min) by the gear ratio. The actual speed is 2%~20% less than the displayed value, depending on the size of the load.
- 希望以大于下表的减速比进行进一步减速时，可在电动机与减速机之间安装减速比为10的中间减速机。这时的容许转矩为20N·m。
To reduce the speed beyond the gear ratio in the table, attach a decimal gearhead(gear ratio:10)between the gearhead and motor. In that case, the permissible torque is 20N·m.

容许力矩单位 Allowance Torque Unit : 上段 Upside (N.m) /下段 Belowside (kgf.cm)

类型 Type 电动机/减速机 Motor/Gearhead	减速比 Gear Ratio		3	3.6	5	6	7.5	9	12.5	15	18	25	30	36	50	60	75	90	100	120	150	180	200	
	转速 Speed r/min	50Hz	500	417	300	250	200	166	120	100	83	60	50	41	30	25	20	16	15	12.5	10	8.3	7.5	
		60Hz	600	500	360	300	240	200	144	120	100	72	60	50	36	30	24	20	18	15	12	10	9	
5IK60GU-AF□ 5IK60GU-EF□ 5IK60GU-CF□ 5IK60GU-HF□ 5IK60GU-SF□	5GU□KB 5GU□K	50Hz	1.1	1.4	1.9	2.3	2.9	3.4	4.8	5.7	6.8	8.6	10	10.3	12.4	15.5	18.6	20	20	20	20	20	20	
			11.2	14.2	19.3	23.4	29.6	34.7	48.9	58.1	69.3	87.7	100	105	126	158	189	200	200	200	200	200	200	
		60Hz	0.92	1.1	1.5	1.8	2.3	2.8	3.8	4.6	5.5	6.9	8.3	8.3	10	12.5	15	18.8	20	20	20	20	20	20
			9.38	11.2	15.3	18.3	23.4	28.5	38.7	46.9	56.1	70.1	84.7	84.6	102	127	153	192	200	200	200	200	200	200

容许悬挂负载·容许轴向负载 To Allow The Hoisting Of The Load Allow Axial Load

电动机(圆轴型)→P272页 Motor(Round Shaft)→P272
减速机→P272页 Gearhead→P272

减速机的容许负载惯性惯量 J Permissible Load Inertia J For Gearhead

→P272页→P272

外形图(单位 mm) Dimensions(Unit mm)

减速器附有安装用螺丝 Mounting screws are included with gearhead.

● 导线型 Lead Wiring Type ①

重量 Weight : 电动机 Motor : 2.7kg 减速器 Gearhead : 1.35kg

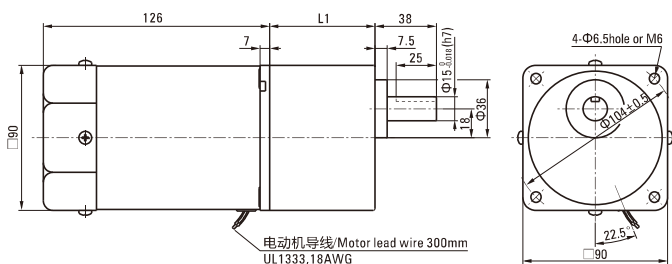

电动机型号 Motor Model	减速器型号 Gearhead Model	减速比 Gear Ratio	L1
5IK60GU-AF 5IK60GU-EF 5IK60GU-CF 5IK60GU-HF 5IK60GU-SF	5GU□KB	3~200	65.5

- 减速器型号的□中为减速比的数值
Enter the gear ratio in the box (□) within the model name

● 带端子箱型 Terminal Box Type ②

重量 Weight : 电动机 Motor : 2.85kg

减速器 Gearhead : 1.5kg

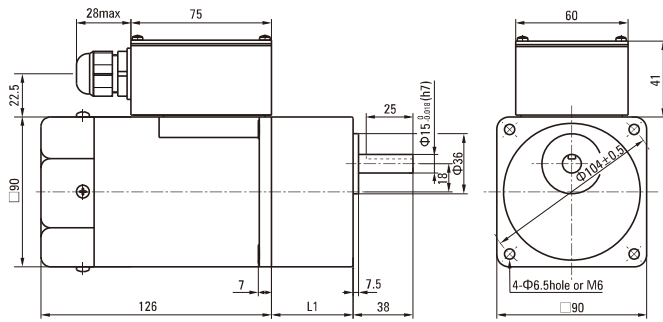

●适用电缆直径为 Use cable with a diameter of $\Phi 6 \sim \Phi 12 \text{mm}$

电动机型号 Motor Model	减速器型号 Gearhead Model	减速比 Gear Ratio	L1
5IK60GU-AFT	5GU□KB	3~200	65.5
5IK60GU-EFT			
5IK60GU-CFT			
5IK60GU-HFT			
5IK60GU-SFT			

●减速器型号的□中为减速比的数值
Enter the gear ratio in the box (□) within the model name

● 凸缘安装型减速器 Flange Mounting Reducer

可安装在GU齿轮轴型上
Can be mounted on GU type gear shaft
5GU□K
重量Weight:1.5kg

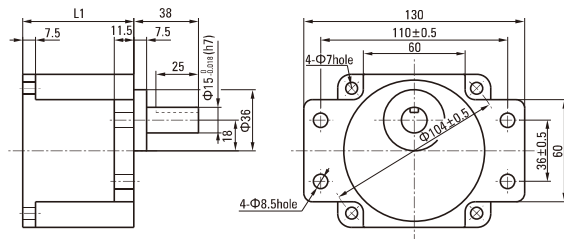

● 键·键槽 (减速器附件)

Key · Keyway(Accessory Of Gearhead)

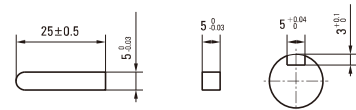

● 圆轴型的转轴部分 Shaft Section Of Round Shaft Type

除重量及轴部外电动机外形与齿轮轴型相同。
Excluding weight and the shaft section motor shape are the same as those of the pinion shaft type.

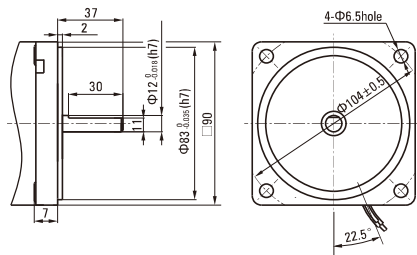

● 中间减速器 Decimal Gearhead

可安装在GU齿轮轴型上Can be connected to GU pinion shaft type
电动机外形与齿轮轴型相同
5GU10XK
重量 Weight : 0.65kg

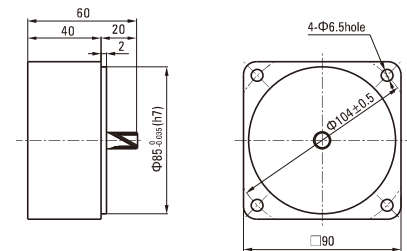

■ 电容器外形尺寸 Formal Dimension Of Capacitor

型号Model	电容器型号 Capacitor Model	L	W	H
5IK60GU-AF□	ZD200CFAUL	47	23	35
5IK60GU-EF□	ZD120CFAUL	47	17	31
5IK60GU-CF□	ZD40BFAUL	47	17	31

● 常规电容器出线为引线,也可根据客户要求配置插片式187#
Note: Conventional capacitor is a lead wire type. Inserted 187# is optional

● 电动机型号的□中为表示带端子箱型的记号(T)
Enter the code that represents the terminal box type (T) in the box (□) within the model name

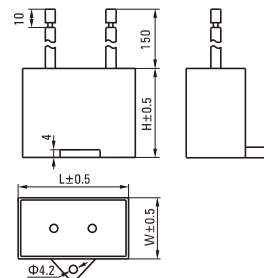

连接图 Wiring Diagram

- 运转方向指从电动机轴看来的方向。CW表示顺时针方向，CCW表示逆时针方向。
The direction of motor rotation is as viewed from the shaft end of motor. CW represents the clockwise direction, while CCW represents the counterclockwise direction.
- 表中所记品名为齿轮轴型，圆轴型亦同。
Name indicated in the list is pinion shaft type, also valid for the equivalent round shaft type.

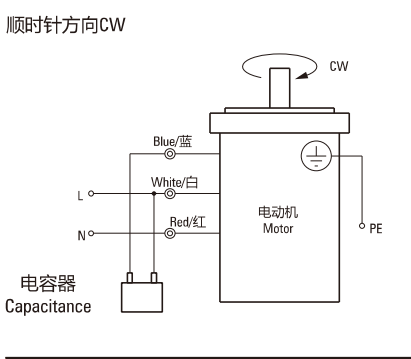
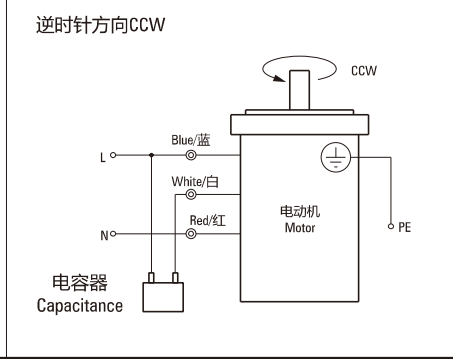
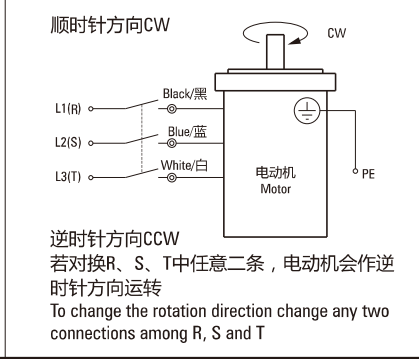
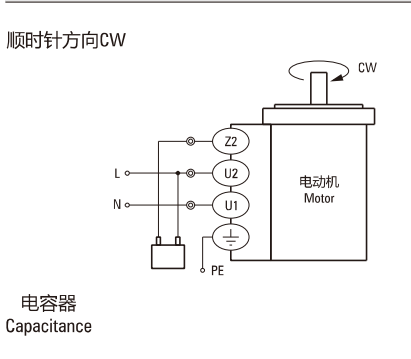
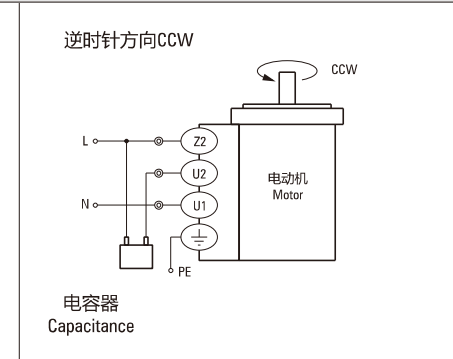
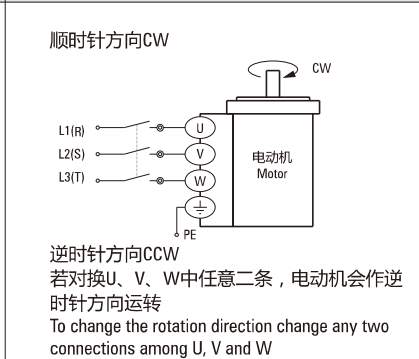
导线型 Lead Wire Type		
5IK60GU-AF、5IK60GU-EF、5IK60GU-HF、5IK60GU-CF		5IK60GU-SF
顺时针方向CW  <p>电容器 Capacitance</p>	逆时针方向CCW  <p>电容器 Capacitance</p>	顺时针方向CW  <p>逆时针方向CCW 若对换R、S、T中任意二条，电动机会作逆时针方向运转 To change the rotation direction change any two connections among R, S and T</p>
带端子箱型 Terminal Box Type		
5IK60GU-AFT、5IK60GU-EFT、5IK60GU-HFT、5IK60GU-CFT		5IK60GU-SFT
顺时针方向CW  <p>电容器 Capacitance</p>	逆时针方向CCW  <p>电容器 Capacitance</p>	顺时针方向CW  <p>逆时针方向CCW 若对换U、V、W中任意二条，电动机会作逆时针方向运转 To change the rotation direction change any two connections among U, V and W</p>

请注意 Note:

单相电动机运转方向的转换应在电动机停止后进行。

Change the direction of single-phase motor rotation only after bringing the motor to a stop.

若在电动机运转时转换运转方向，可能发生无法转换运转方向或须费时较久的情况。

If an attempt is made to change the direction of rotation while the motor is rotating, motor may ignore reversing command or change its direction of rotation after some delay.