

感应电动机 INDUCTION MOTORS

■ 40W □ 90mm

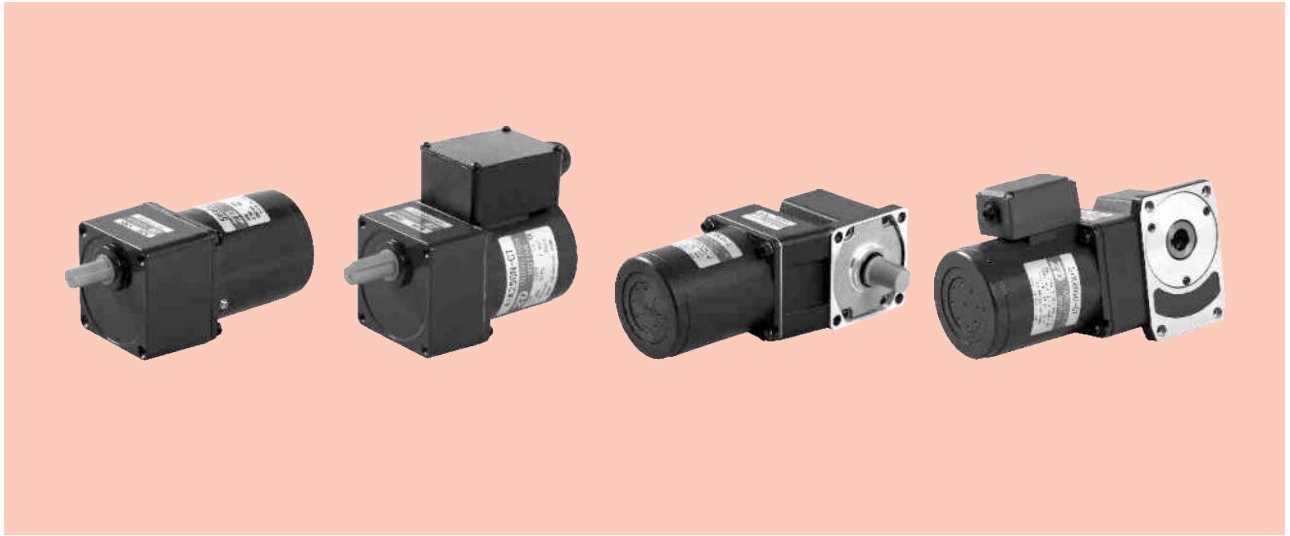

规格 Specs 连续额定 Continuous Rating

型号Model · 类型 Type 上段:齿轮轴 Upper:Pinion Shaft 下段()内:圆轴 Below:Round Shaft		输出功率 Output power W	电压 Voltage V	频率 Frequency Hz	电流 Current A	启动转矩 Starting Torque mN.m	额定转矩 Rated Torque mN.m	额定转速 Rated Speed r/min	电容器容量 Capacitor μF
导线型 Lead Wire Type 外形图Dimensions①	带端子箱型 Terminal Box Type 外形图Dimensions②								
5IK40GN-A (5IK40A-A)	5IK40GN-AT (5IK40A-AT)	40	1ph 100	50	0.65	220	315	1250	12.0
				60	0.70		260	1550	
5IK40GN-E (5IK40A-E)	5IK40GN-ET (5IK40A-ET)	40	1ph 110	60	0.55	200	260	1550	8.0
			1ph 120		0.60				
5IK40GN-C (5IK40A-C)	5IK40GN-CT (5IK40A-CT)	40	1ph 220	50	0.35	220	315	1250	2.5
			1ph 230		0.40				
5IK40GN-H (5IK40A-H)	5IK40GN-HT (5IK40A-HT)	40	1ph 220	60	0.35	200	260	1550	-
			1ph 230		0.40				
5IK40GN-S (5IK40A-S)	5IK40GN-ST (5IK40A-ST)	40	3ph 220	50	0.30	800	315	1250	-
				60	0.25	660	250	1550	

●各种安全规格以电动机铭牌上的型号名取得认证。

When the motor is approved under various safety standards, the model name on the nameplate is the approved model name.

●注：90-40W直角减速电机均为(GU)加强型。 Note:90-40W right angle gear motor all motor is (GU)strength type.

●注：“-A”型号中电压为110V时，配置电容器容量以实际铭牌为准。 Note:“-A” it means the voltage 110v,the assembly capacitor vaule it is according the labe.

种类 Type

● 电动机 Motor

机型 Type	型号Model	
	齿轮轴型 Pinion Shaft	圆轴型 Round Shaft
导线型 Lead Wire Type	5IK40GN-A	5IK40A-A
	5IK40GN-E	5IK40A-E
	5IK40GN-C	5IK40A-C
	5IK40GN-H	5IK40A-H
	5IK40GN-S	5IK40A-S
带端子箱型 Terminal Box Type	5IK40GN-AT	5IK40A-AT
	5IK40GN-ET	5IK40A-ET
	5IK40GN-CT	5IK40A-CT
	5IK40GN-HT	5IK40A-HT
	5IK40GN-ST	5IK40A-ST

● 平行轴减速器 (另售) Parallel Shaft Gearhead (Sold Separately)

减速器种类 Gearhead Type	减速器型号 Gearhead Model	减速比 Gear Ratio
长寿命●低噪音 Long Life ● Low Noise	5GN□K	3、3.6、5、6、7.5、9、12.5、15、18、25、30、36、50、60、75、90、100、120、150、180、200
	5GN10XK (中间减速器 Decimal Gearhead)	

●减速器型号的□中为减速比的数值

Enter the gear ratio in the box (□) within the model name

■ 装有减速器时的容许转矩 Gear Motor-Torque Table

- 减速器另售·中间减速器另售。电动机型号的□中为表示带端子箱型的记号(T)。
Gearhead and mid-gearbox can be sold separately. Enter the code that represents the terminal box type (T) in the box (□) within the model name.
- 减速品型号的□中为减速比的数值。
Enter the gear ratio in the box(□) within the model name.
- □色表示与电动机同一方向运转，其他则为相反方向。
The colored background □ indicates the same rotating direction of the motor while the rotating direction of others are opposite.
- 转速是以电动机的同步转速(50Hz:1500r/min、60Hz:1800r/min)为基准除以减速比而算出来的数值。实际转速将随负载大小变化所示数值减少2%~20%左右。
The speed is calculated by dividing the motor's synchronous speed(50Hz:1500r/min、60Hz:1800r/min) by the gear ratio. The actual speed is 2%~20% less than the displayed value, depending on the size of the load.
- 希望以大于下表的减速比进行进一步减速时，可在电动机与减速机之间安装减速比为10的中间减速机。这时的容许转矩为10N·m。
To reduce the speed beyond the gear ratio in the table, attach a decimal gearhead(gear ratio:10)between the gearhead and motor. In that case, the permissible torque is 10N·m.

■ 容许力矩单位 Allowance Torque Unit : 上段 Upside (N.m) /下段 Belowside (kgf.cm)

类型 Type 电动机/减速机 Motor/Gearhead	减速比 Gear Ratio		3	3.6	5	6	7.5	9	12.5	15	18	25	30	36	50	60	75	90	100	120	150	180	200	
	转速 Speed r/min	50Hz	500	417	300	250	200	166	120	100	83	60	50	41	30	25	20	16	15	12.5	10	8.3	7.5	
		60Hz	600	500	360	300	240	200	144	120	100	72	60	50	36	30	24	20	18	15	12	10	9	
5IK40GN-A□ 5IK40GN-E□ 5IK40GN-C□ 5IK40GN-H□ 5IK40GN-S□	5GN□K	50Hz	0.77	0.92	1.3	1.5	1.9	2.3	3.2	3.8	4.6	5.7	6.9	8.3	10	10	10	10	10	10	10	10	10	
			7.85	9.38	13.2	15.3	19.4	23.4	32.6	38.7	46.9	58.1	70.4	84.7	100	100	100	100	100	100	100	100	100	
		60Hz	0.63	0.76	1.1	1.3	1.6	1.9	2.6	3.2	3.8	4.7	5.7	6.8	8.6	10	10	10	10	10	10	10	10	10
			6.42	7.75	11.2	13.2	16.3	19.3	26.5	32.6	38.7	47.9	58.1	69.3	87.7	100	100	100	100	100	100	100	100	100

■ 容许悬挂负载·容许轴向负载 To Allow The Hoisting Of The Load Allow Axial Load

电动机(圆轴型)→P272页

Motor(Round Shaft)→P272

减速机→P272页

Gearhead→P272

■ 减速机的容许负载惯性惯量 J Permissible Load Inertia J For Gearhead

→P272页→P272

■ 外形图(单位 mm) Dimensions(Unit mm)

减速机附有安装用螺丝 Mounting screws are included with gearhead.

● 导线型 Lead Wiring Type ①

重量 Weight : 电动机 Motor : 2.4kg

减速机 Gearhead : 1.35kg

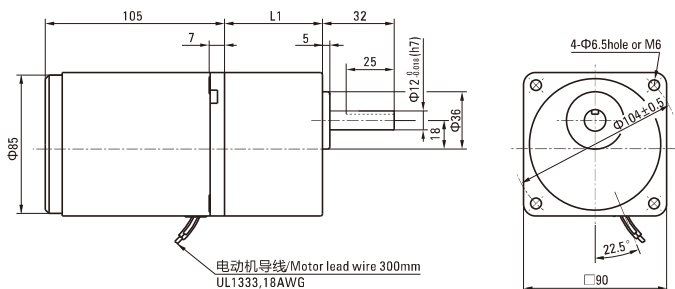

电动机型号 Motor Model	减速机型号 Gearhead Model	减速比 Gear Ratio	L1
5IK40GN-A 5IK40GN-E 5IK40GN-C	5GN□K	3~18	42
5IK40GN-H 5IK40GN-S		25~200	60

- 减速机型号的□中为减速比的数值
Enter the gear ratio in the box (□) within the model name

● 带端子箱型 Terminal Box Type ②

重量 Weight : 电动机 Motor : 2.55kg

减速器 Gearhead : 1.35kg

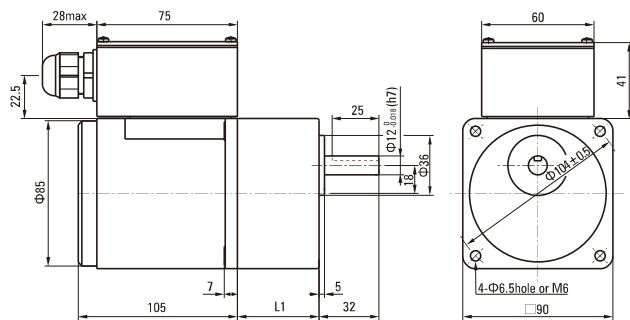

电动机型号 Motor Model	减速器型号 Gearhead Model	减速比 Gear Ratio	L1
5IK40GN-AT	5GN□K	3~18	42
5IK40GN-ET		25~200	
5IK40GN-CT	5GN□K	3~18	60
5IK40GN-HT		25~200	
5IK40GN-ST	5GN□K	3~18	60

● 减速器型号的□中为减速比的数值
Enter the gear ratio in the box (□) within the model name

● 键 - 键槽 (减速器附件) Key - Keyway(Accessory Of Gearhead)

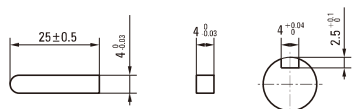

● 圆轴型的转轴部分 Shaft Section Of Round Shaft Type

除重量及轴部外电动机外形与齿轮轴型相同。

Excluding weight and the shaft section motor shape are the same as those of the pinion shaft type.

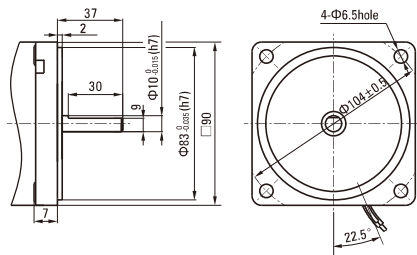

● 中间减速器 Decimal Gearhead

可安装在GN齿轮轴型上 Can be connected to GN pinion shaft type

电动机外形与齿轮轴型相同

5GN10XK

重量 Weight : 0.6kg

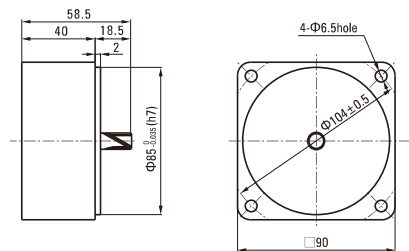

■ 电容器外形尺寸 Formal Dimension Of Capacitor

型号 Model		电容器型号 Capacitor Model	L	W	H
齿轮轴型 Pinion Shaft	圆轴型 Round Shaft				
5IK40GN-A□	5IK40A-A□	ZD120CFAUL	47	17	31
5IK40GN-E□	5IK40A-E□	ZD80CFAUL	48	26.5	38
5IK40GN-C□	5IK40A-C□	ZD25BFAUL	38	17	28

● 常规电容器出线为引线,也可根据客户要求配置插片式187#

Note: Conventional capacitor is a lead wire type. Inserted 187# is optional

● 电动机型号的□中为表示带端子箱型的记号(T)

Enter the code that represents the terminal box type (T) in the box (□) within the model name

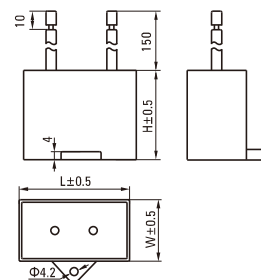

连接图 Wiring Diagram

- 运转方向指从电动机轴看来的方向。CW表示顺时针方向，CCW表示逆时针方向。
The direction of motor rotation is as viewed from the shaft end of motor. CW represents the clockwise direction, while CCW represents the counterclockwise direction.
- 表中所记品名为齿轮轴型，圆轴型亦同。
Name indicated in the list is pinion shaft type, also valid for the equivalent round shaft type.

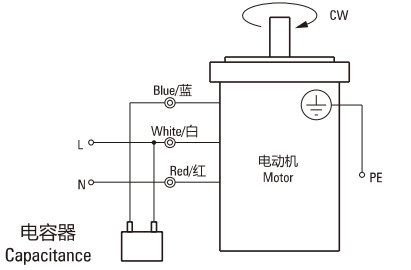
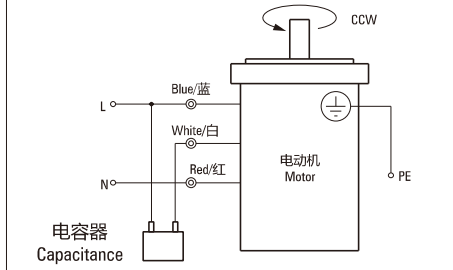
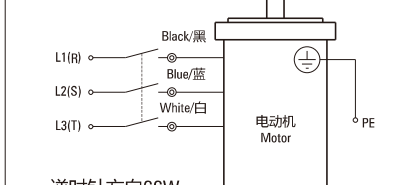
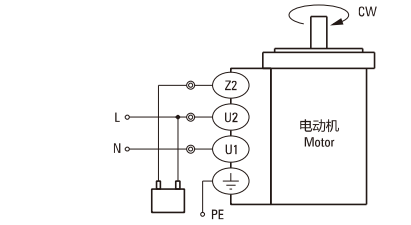
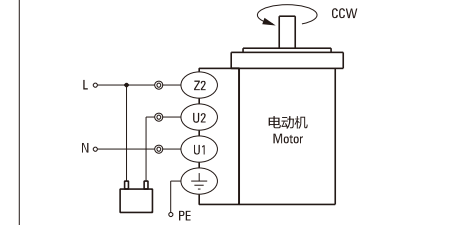
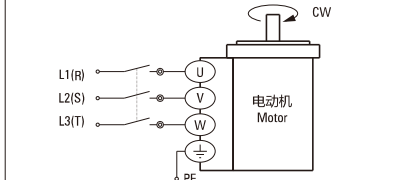
导线型 Lead Wire Type		
5IK40GN-A、5IK40GN-E、5IK40GN-H、5IK40GN-C		5IK40GN-S
顺时针方向CW  <p>电容器 Capacitance</p>	逆时针方向CCW  <p>电容器 Capacitance</p>	顺时针方向CW  <p>电动机 Motor</p> <p>逆时针方向CCW 若对换R、S、T中任意二条，电动机会作逆时针方向运转 To change the rotation direction change any two connections among R, S and T</p>
带端子箱型 Terminal Box Type		
5IK40GN-AT、5IK40GN-ET、5IK40GN-HT、5IK40GN-CT		5IK40GN-ST
顺时针方向CW  <p>电动机 Motor</p> <p>电容器 Capacitance</p>	逆时针方向CCW  <p>电动机 Motor</p> <p>电容器 Capacitance</p>	顺时针方向CW  <p>电动机 Motor</p> <p>逆时针方向CCW 若对换U、V、W中任意二条，电动机会作逆时针方向运转 To change the rotation direction change any two connections among U, V and W</p>

请注意 Note:

单相电动机运转方向的转换应在电动机停止后进行。

Change the direction of single-phase motor rotation only after bringing the motor to a stop.

若在电动机运转时转换运转方向，可能发生无法转换运转方向或须费时较久的情况。

If an attempt is made to change the direction of rotation while the motor is rotating, motor may ignore reversing command or change its direction of rotation after some delay.